

SmartBoard

System description



Table of contents

Table of contents

1	Information about this document.....	5
1.1	Validity.....	5
1.2	Symbols used	5
2	Basic security information	6
2.1	Proper use	6
2.2	Obvious misuse	6
2.3	Qualification and knowledge of personnel	6
2.4	Structure and explanation of warnings.....	6
2.5	General safety instructions	7
2.6	Personal protection equipment	7
2.7	Avoiding electrostatic charge and uncontrolled discharging (ESD)	8
2.8	SmartBoard for ADR (GGVS) vehicles	9
3	System description.....	10
3.1	Technical data.....	11
3.2	Connection.....	12
3.3	System configuration	13
3.4	Compliance with standards.....	14
4	Assembly.....	15
4.1	Preparatory measures	15
4.2	Alignment.....	15
4.3	Installation on the vehicle.....	17
5	Operation	18
6	Functions.....	20
6.1	ECAS air suspension	20
6.1.1	1-point control.....	21
6.1.2	2-point control Drawbar trailer.....	21
6.1.3	2-point control Semitrailer	22
6.1.4	Normal level	22
6.1.5	Memory level.....	23
6.2	Axle load indicator.....	23
6.3	Bounce Control	24
6.4	Brake lining wear	24
6.5	Release brakes	25
6.6	Trailer length	25
6.7	Diagnostic memory	26
6.8	Electronic parking brake	27
6.9	Lifting axle control.....	27
6.9.1	Lifting axle control	28
6.9.2	Disable lifting axle(s).....	28
6.9.3	OptiTurn™	29
6.9.4	Traction help.....	30

Original document:

The German version is the original document.

Translation of the original document:

All non-German language editions of this document are translations of the original document.

Edition 1, Version 1 (09.2020)

Document no.: 815 010 260 3 (en)



You will find the current edition at:
<http://www.wabco.info/i/1665>

6.9.5	OptiLoad™	31
6.9.6	Odometer	32
6.10	SafeStart	32
6.11	Automatic steering axle	33
6.12	Vehicle inclination	33
6.13	Work light control	34
6.14	Road finisher brake	34
6.15	OptiTire™	34
6.16	Freely configurable GIO functions (GIO FCF)	35
6.17	Settings	36
6.17.1	Units	37
6.17.2	Screen saver	37
6.17.3	Axle load calibration	39
6.17.4	Brightness	41
6.17.5	Time / date	42
6.17.6	Start screen	42
6.17.7	Axle overload	43
6.17.8	OptiTire™ functions	43
6.17.9	Reorder functions in the main menu	45
6.17.10	Odometer settings	46
6.17.11	CAN termination	47
6.17.12	Language	48
6.17.13	Change immobilizer PIN/PUK	48
6.17.14	Reset to factory settings	49
6.18	Info	49
6.18.1	Trailer info	50
6.18.2	System info	50
6.18.3	ODR data	51
6.18.4	Operating temperature	51
6.18.5	Terminal 30 (tl. 30)	52
6.19	Immobilizer	52
6.20	Emergency release (immobilizer)	53
7	Maintenance and care	54
7.1	Maintenance	54
7.2	Replacement part sets	54
7.3	Changing the battery	54
7.4	Cleaning	55
8	Storage	56
9	Disposal	56
10	Fault codes	57
11	Electronic Extension Module fault codes	59
12	WABCO regional offices	68

1 Information about this document

1.1 Validity

This document applies to the following WABCO part numbers:

446 192 210 0

446 192 211 0

1.2 Symbols used

i Important information, notes and/or tips

Descriptive text

– for action steps

1. Action step 1

2. Action step 2

⇒ Consequence of an action

• Listing

Basic security information

2 Basic security information

2.1 Proper use

The SmartBoard is an electronic remote control unit that is designed for use on trailer vehicles with electronic braking systems (TEBS).

2.2 Obvious misuse

The SmartBoard with an integrated battery (446 192 210 0) may not be installed on hazardous goods vehicles. For more information on this, please see chapter "2.8 SmartBoard for ADR (GGVS) vehicles", page 9.

2.3 Qualification and knowledge of personnel

This publication is meant for commercial vehicle workshop personnel with knowledge of automotive electronics, as well as vehicle drivers.

2.4 Structure and explanation of warnings

Warnings are structured as follows:

- Signal word and pictogram
- Correct naming of the hazard
- Description of the consequences if the hazard is ignored
- Description of the measure(s) to prevent the danger

DANGER

Indicates a hazard that will result in death or serious injury if not avoided.

WARNING

Indicates a hazard that may result in death or serious injury if not avoided.

CAUTION

Indicates a hazard that may result in slight or moderately serious injury if not avoided.

NOTICE

Indicates a hazard that may result in material damage if not avoided.

Basic security information

2.5 General safety instructions

- Follow all safety information, instructions and notices in this document to avoid personal injury and material damage.
- Follow regional and national regulations on accident prevention.
- Follow the respective vehicle manufacturer's specifications and instructions.
- Ensure the utmost cleanliness throughout installation.
- Make sure your workplace is dry as well as adequately lit and ventilated.
- Secure the vehicle against rolling by using chocks.
- Ensure that the service brake is not being actuated when working on the brake. Attach a notice to the steering wheel stating that work is being carried out on the vehicle.
- Only use spare parts approved by WABCO or the vehicle manufacturer.
- Do not use motor-powered screwdriver or torque tools.
- Never open the SmartBoard housing (with the exception of the battery compartment on unit 446 192 210 0 to change the battery) as this will invalidate the warranty.

2.6 Personal protection equipment

- Please wear personal protection equipment during installation to prevent injuries:
 - Safety boots
 - Safety goggles
 - Protective gloves
 - Ear protectors

Basic security information

2.7 Avoiding electrostatic charge and uncontrolled discharging (ESD)

⚠ WARNING

Fire hazard due to lithium-ion battery!

In the event of an accident or improper handling, damaged or defective lithium-ion batteries can cause fires that are difficult to extinguish. Use of the battery-operated SmartBoard (product number 446 192 210 0) on hazardous goods vehicles is therefore prohibited.

- Only install the battery-free SmartBoard (product number 446 192 211 0) on hazardous goods vehicles.

Note during construction and building of the vehicle:

- Prevent potential differences between components (e.g. axles) and the vehicle frame (chassis). Make sure that the resistance between metallic parts of the components and the vehicle frame is less than 10 Ohm (< 10 Ohm). Establish an electrically conductive connection between moving or insulated vehicle parts, such as axles, and the frame.
- Prevent potential differences between the towing vehicle and the trailer. Make sure that an electrically conductive connection is made between metal parts in the towing vehicle and the coupled trailer via the coupling (king pin, fifth wheel, claws with pins), even without a cable being connected.
- Use electrically conductive bolted connections when fastening the ECUs to the vehicle frame.
- Use only cable conforming to WABCO specifications or original WABCO cable.
- Run the cable in metallic casing if at all possible (e.g. inside the U-beam) or behind metallic and grounded protective plating to minimise the influence of electro-magnetic fields.
- Avoid the use of plastic materials if they can cause electrostatic charging.

While carrying out repair or welding work on the vehicle, observe the following:

- Disconnect the battery (if installed in the vehicle).
- Disconnect cable connections to devices and components and protect connectors and ports against contamination.
- Always connect the grounding electrode directly with the metal next to the welding point when welding to prevent magnetic fields and current flow via the cable or components. Make sure that current is well conducted by removing paint or rust.
- Prevent heat influences on devices and cabling when welding.

Basic security information

2.8 SmartBoard for ADR (GGVS) vehicles

A version of the SmartBoard has been developed for use on hazardous goods vehicles that is not equipped with an internal battery (product number 446 192 211 0).

The connection dimensions, cable connections and mounting are unchanged (see chapter "4 Assembly", page 15).

Operation is identical to the standard version (product number 446 192 210 0). Some functions are restricted by battery-free operation of the SmartBoard 446 192 211 0:

- No date and time function
- No saving of messages
- No internal odometer in the SmartBoard (the odometer reading of the Trailer EBS is still displayed)
- Information shown on the display only when the trailer is powered up

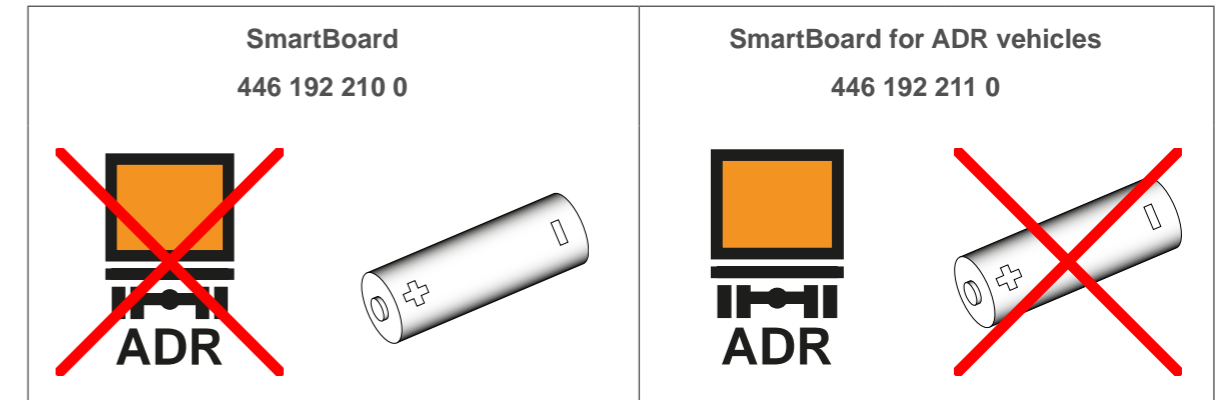

i

ADR/GGVSE certificates for hazardous goods vehicles

WABCO provides ADR/GGVSE certificates for a range of hazardous goods vehicles.

Please contact your WABCO partner to request an ADR/GGVSE certificate for your vehicle.

3 System description

The SmartBoard is an on-board display for monitoring data from connected electronic systems. Malfunctions, the odometer, load information, the pad wear indicator and other information are displayed on a monochrome LCD graphic display. In addition, several trailer functions can be controlled (e.g. air suspension functions).

The SmartBoard is mounted on the frame of the trailer. The unit has a cable that connects it to the diagnostic plug on the trailer or directly to a control unit.

It is supplied with power via the diagnostic cable from the connected system or via the integrated battery (SmartBoard 446 192 210 0). Some of the data from the connected system (e.g. error messages, brake lining wear or operating data) is stored on the SmartBoard while the system is running. This data can be read if the connected system has no power supply.

The SmartBoard can replace various devices that are optionally installed on trailers, such as an odometer in a wheel hub, axle load indicator, brake lining wear indicator and tyre pressure indicator (OptiTire™).

Optionally, the SmartBoard can operate as a stand-alone odometer by using the wheel speed measured by a connected ABS wheel speed sensor. In this case the SmartBoard must be powered by an integrated battery (SmartBoard 446 192 210 0).

The SmartBoard is compatible with TEBS E (version E 4 or higher).

3.1 Technical data

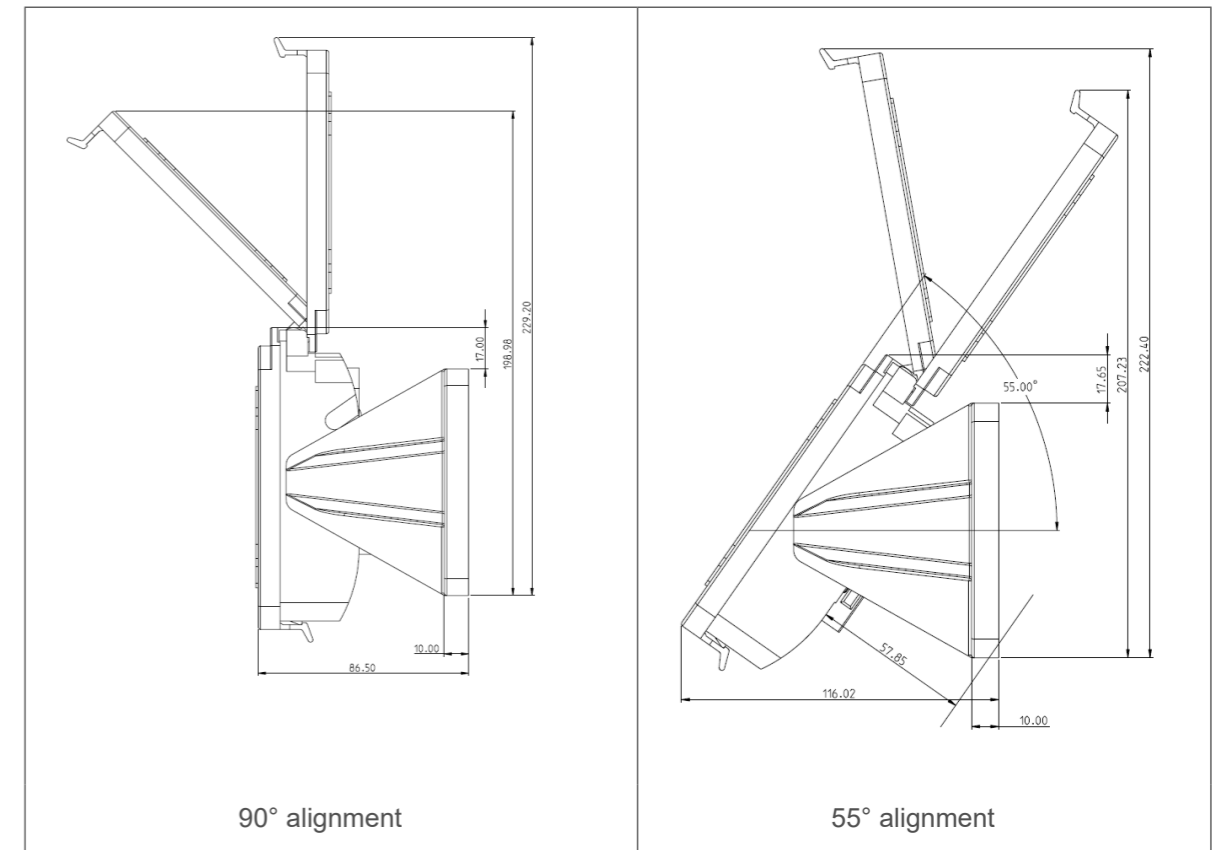

L x W x H dimensions (mm)	229.2 x 171.0 x 86.5 (90° alignment) 222.4 x 171.0 x 116.0 (55° alignment)
Weight (kg)	0.50 (446 192 211 0) 0.53 (446 192 210 0)
Operating voltage (V)	8 – 32
Operating temperature (°C)	-40 – 65
Display operating temperature (°C)	-30 – 65
Short-term temperature resistance (°C)	max. 85 (1 hour)
Protection class (with the protective cover closed)	IP6K9K

System description

3.2 Connection

The SmartBoard must be connected to an 8-pin HDSCS (Heavy Duty Sealed Connector) plug (MCP, code B) for industrial and commercial vehicles.

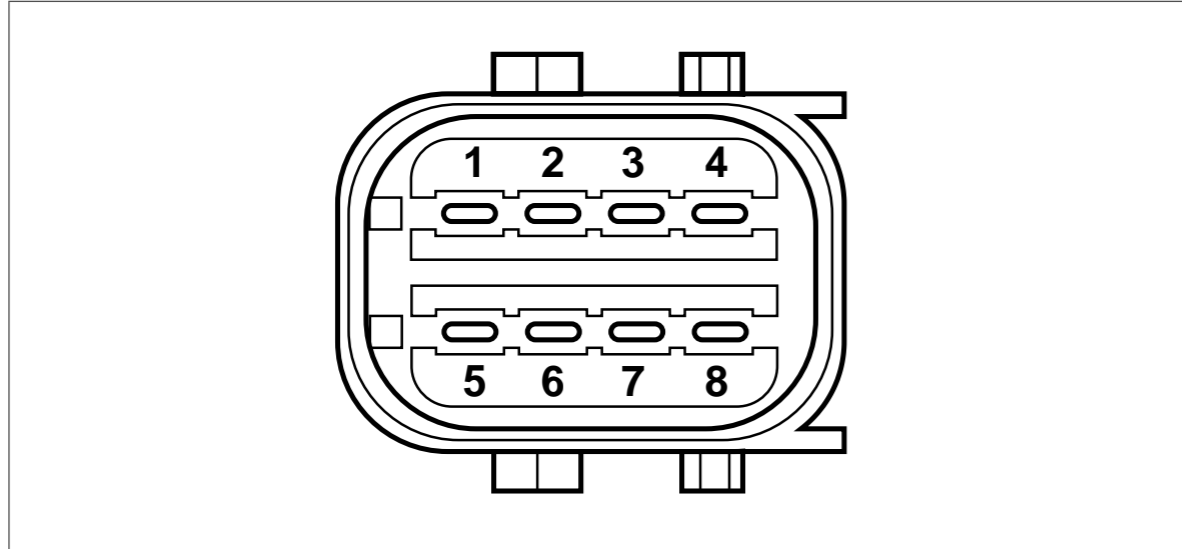

Pin	Assignment
1	CAN low
2	CAN high
3	Wheel speed sensor
4	Wheel speed sensor
5	Not used
6	Not used
7	Supply connection (electrical)
8	Ground

System description

3.3 System configuration

The range of SmartBoard functions depends on the Trailer EBS / Trailer ABS version and on the components installed on the trailer.

The SmartBoard is compatible with the following components (available separately):

- Lift Axle Control Valve
- ECAS solenoid valve
- OptiTire™
- Brake lining wear indicator (BVA)



System description

3.4 Compliance with standards

Document	Name	Version
ISO 10605	Road vehicles - Test methods for electrical disturbances from electrostatic discharge	2008 - 07
ISO 16750 - 2	Road vehicles - Environmental conditions and testing for electrical and electronic equipment - Part 2: Electrical loads	2012 - 11
ISO 16750 - 3	Road vehicles - Environmental conditions and testing for electrical and electronic equipment - Part 3: Mechanical loads	2012 - 12
ISO 16750 - 4	Electrical and electronic vehicle equipment - Environmental conditions - Part 4: Climatic loads	2010 - 04
ISO 16750 - 5	Electrical and electronic vehicle equipment - Environmental conditions - Part 5: Chemical loads	2010 - 04
ISO 7637 - 2	Road vehicles - Electrical disturbances from conduction and coupling - Part 2: Electrical conduction disturbances along supply lines	2011 - 03
ISO 7637 - 3	Road vehicles - Electrical disturbances from conduction and coupling - Part 3: Electrical transient transmission by capacitive and inductive coupling via lines other than supply lines	2007 - 07
CISPR 25	Vehicles, boats and internal combustion engines - Radio disturbance characteristics - Limits and methods of measurement for the protection of on-board receivers	2008 - 03
ISO 11452 - 4	Road vehicles - Component test methods for electrical disturbances from narrowband radiated electromagnetic energy - Part 4: Harness excitation methods	2011 - 12
ISO 20653	Road vehicles - Degrees of protection (IP code) - Protection of electrical equipment against foreign objects, water and access	2013 - 02

Assembly

4 Assembly

Only install the battery-free SmartBoard on hazardous goods vehicles (see chapter "2.8 SmartBoard for ADR (GGVS) vehicles", page 9).

4.1 Preparatory measures

- Before you begin installing, upgrading, repairing or replacing the SmartBoard, follow the instructions in chapter "2 Basic security information", page 6.
- Disconnect the power supply to the towing vehicle.
- Secure the vehicle against the risk of short-circuit. To do so, follow the instructions in chapter "2.7 Avoiding electrostatic charge and uncontrolled discharging (ESD)", page 8.
- Select an installation location on the vehicle frame that is easily accessible for the user and that can be reached by the planned connecting cable.
- Select an installation location that is protected from spray water.

4.2 Alignment

The SmartBoard can be aligned at two different angles (90° and 55°):

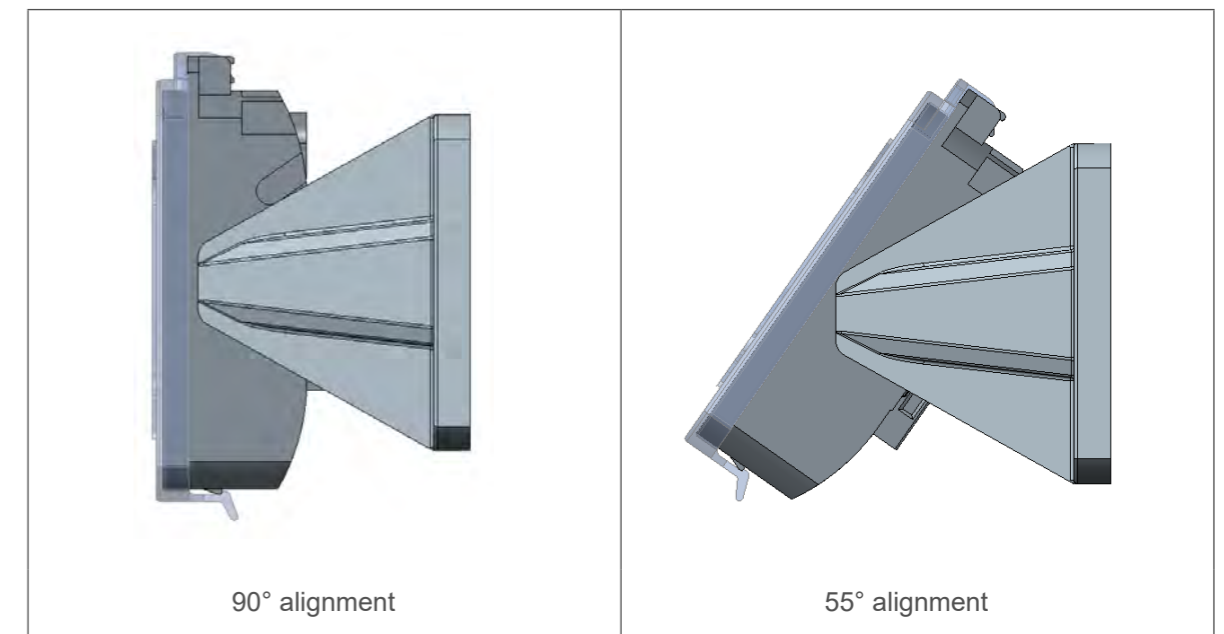

Assembly

Changing the alignment

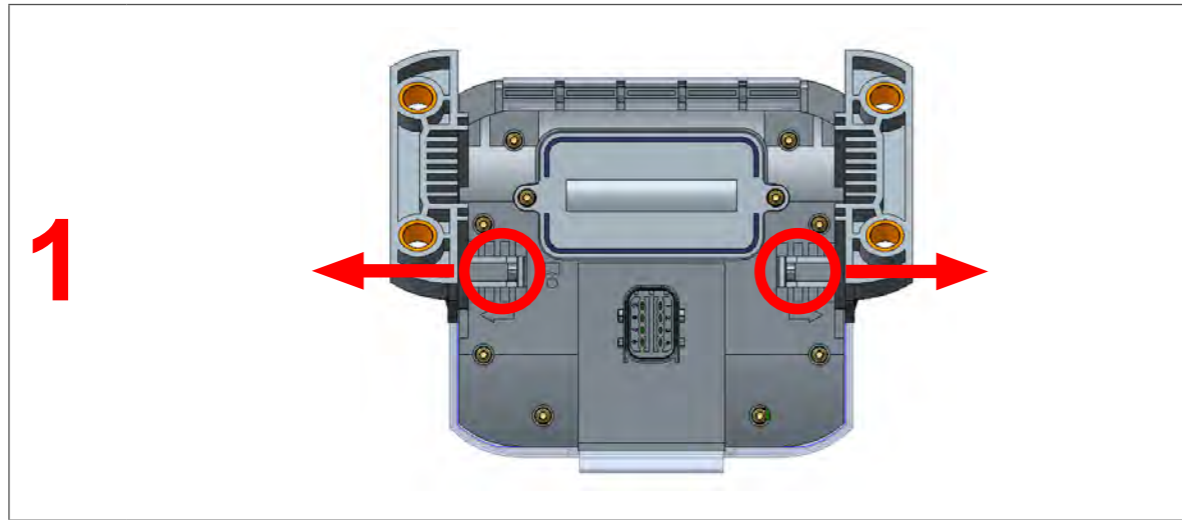

- Push the two retaining clips on the back of the SmartBoard outwards (1) while pulling the brackets out of the guides.

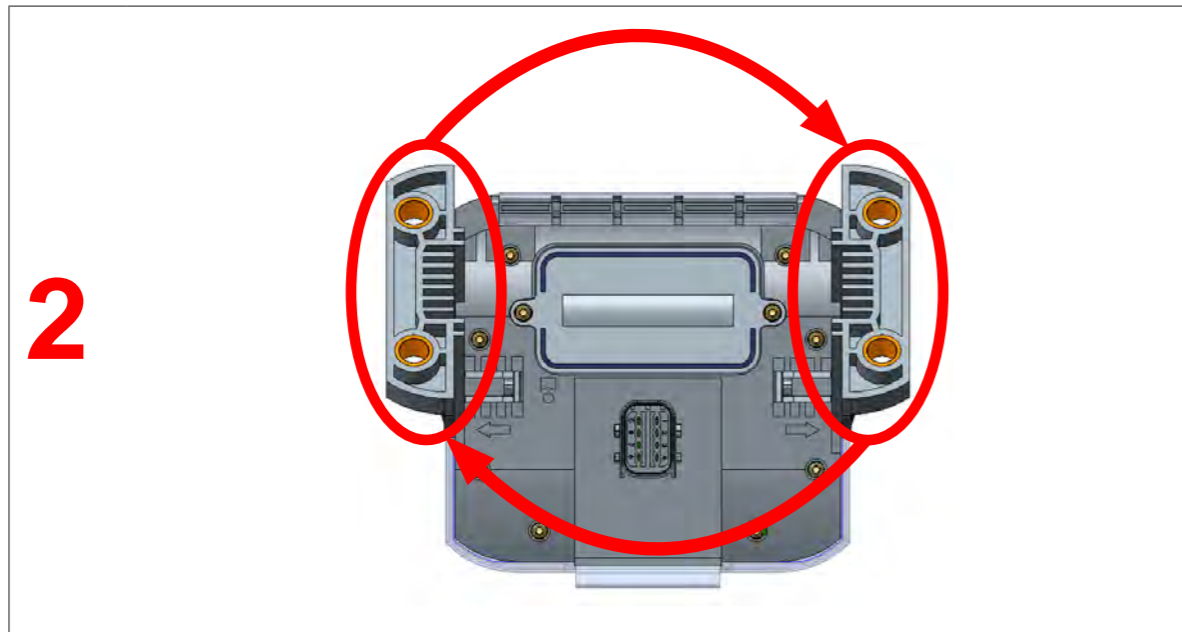

- Switch the brackets from one side to the other (2).
- Push the brackets into the guides until you hear them click into place.
 - ⇒ The orientation of the SmartBoard is changed.

Assembly

4.3 Installation on the vehicle

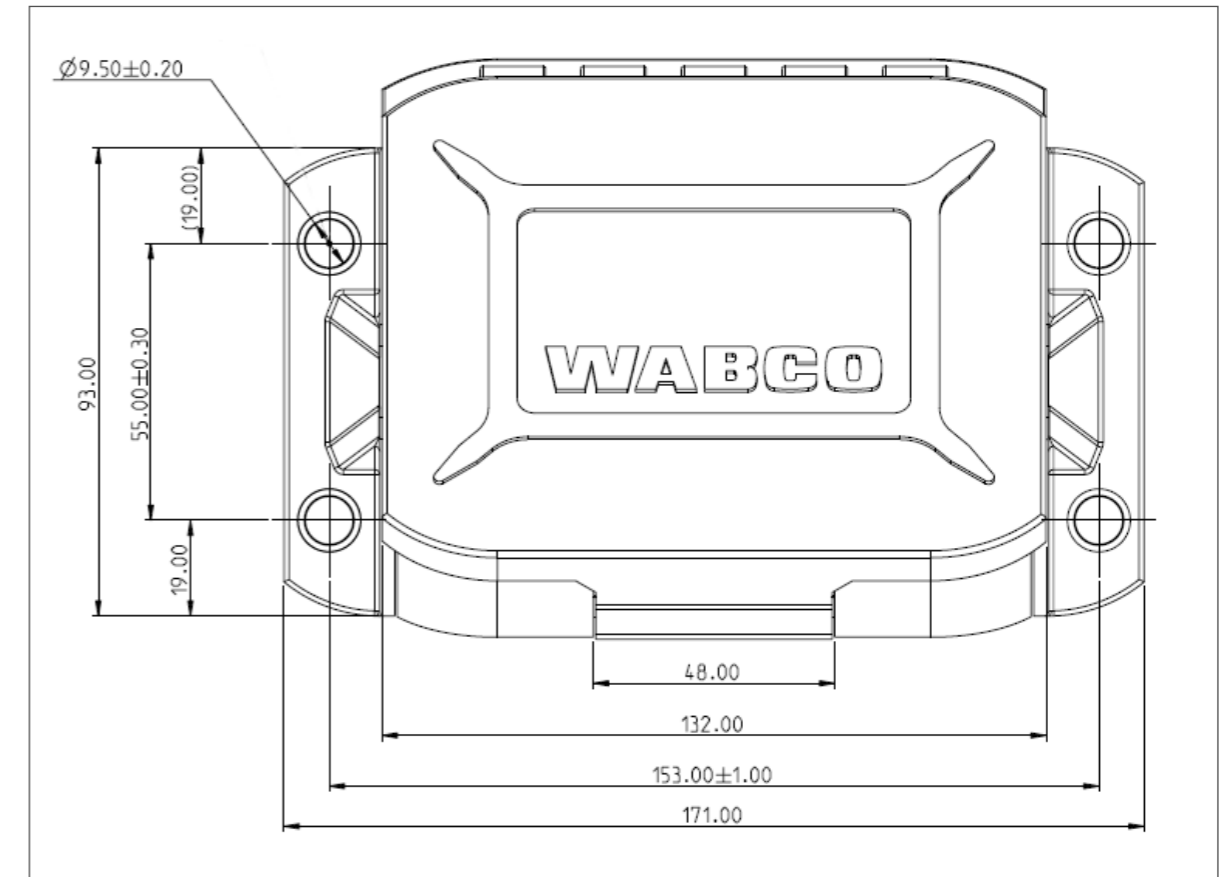

- Use the dimensions in the technical drawing to drill the holes (chapter "5 Operation", page 18).
- Fasten the SmartBoard to the vehicle frame with four M8 screws and tighten the screws. Maximum tightening torque: 15 Nm.
- Install cables according to the circuit diagram in parallel with already existing wiring harnesses. Form large loops from ample lengths.
- Cable the SmartBoard with the Trailer EBS modulator. Press the cable plug-connector into the slot applying a little initial force. All connections must be assigned a cable or have a closing cap.
- Fasten the cable only on solid elements that are connected with the components, e.g. the vehicle frame. Fastening cables to flexible elements can cause cable breakages and the seal could break.
- Fasten the cables and connectors so that the plug connections are not subjected to any tensile stress or lateral forces. Avoid laying cables across sharp edges or near aggressive media (acids for example).
- Fasten the cable a maximum of 30 cm after the device, e.g. with a cable tie.

Operation



5 Operation

- Press any button to start the SmartBoard.
- ⇒ The main menu is displayed.

i If the charge level of the internal battery is too low, the battery-operated SmartBoard (product number 446 192 210 0) may not start.

Symbols

Active functions are displayed with the opposite colouring.

Active function	Inactive function
	

Using the SmartBoard main menu

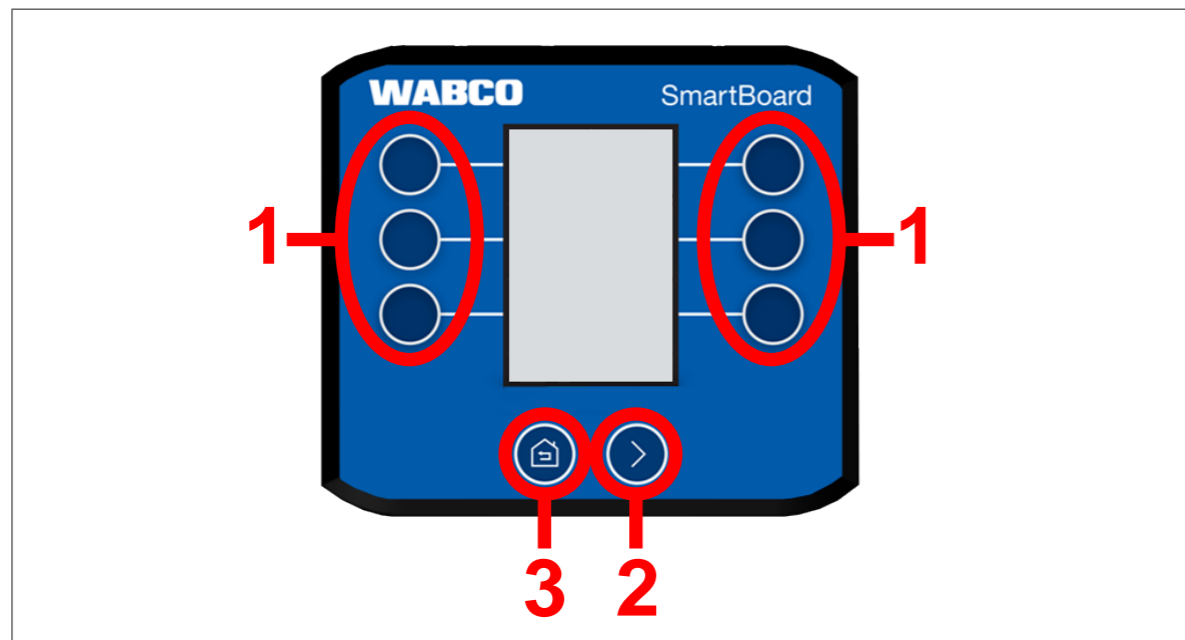

The keys carry out the following functions in the main menu:

- Press one of the **1** keys to select the SmartBoard function displayed next to each key.
- Press key **2** to navigate through the different pages of the main menu.
- Press key **3** to return to the first page of the main menu.

Operation

Using a SmartBoard submenu

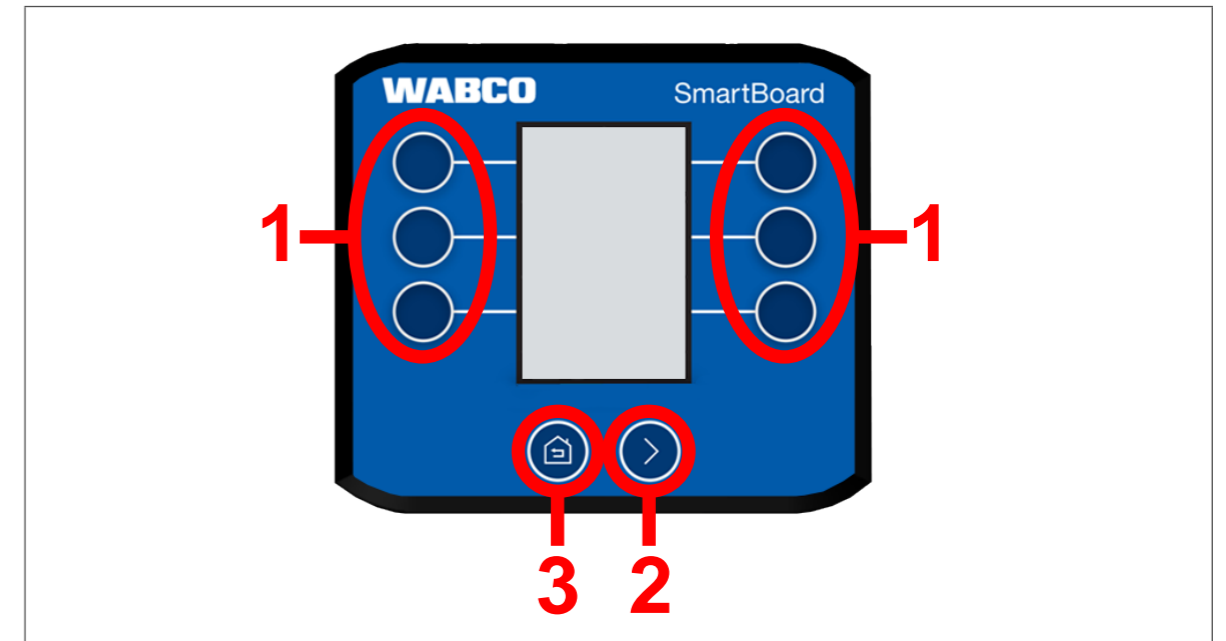

The keys carry out the following functions in a submenu:

- Press one of the **1** keys to select the SmartBoard function displayed next to each key.
- Press key **2** to navigate through the different pages of the function.
- Press key **3** to return to the next menu level up.
- Hold down key **3** for two seconds to go back to the last page displayed in the main menu.

Display

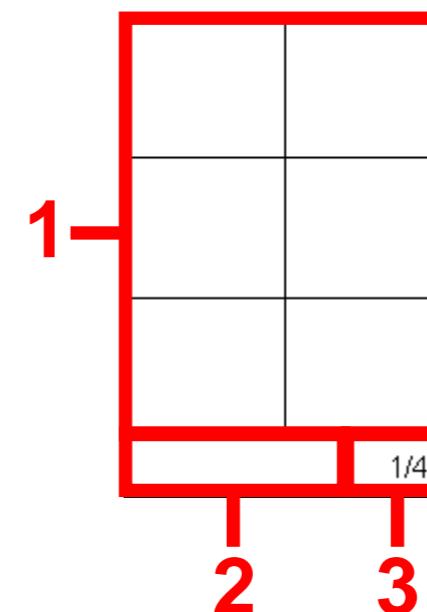

The different areas of the display show the following information:

- 1** Functions/information.
- 2** Diagnostic messages and active systems. A submenu also shows which submenu the user is in. Warnings are also shown here.
- 3** Current page of the respective menu.

Functions

6 Functions

i The illustrations shown in this chapter may differ in places from the actual illustrations. Depending on the configuration of the vehicle (drawbar trailer, central axle trailer, semitrailer, number of axles, etc.), the illustrations on the display or individual functions may change.

In order to illustrate how the SmartBoard works, the keys in the following chapters are assigned names according to the diagram shown below:

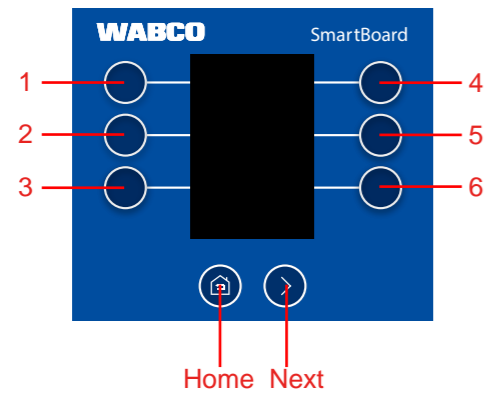

6.1 ECAS air suspension

i If ECAS is installed, it must first be brought to the normal level. Installed lifting axles must be lowered.
For proper operation of the system, all load statuses must be calibrated. See also chapter "6.17.3 Axle load calibration", page 39.

Select air suspension (ECAS) manual lifting / lowering or predefined levels.

SmartBoard - ECAS			
Key	Description	Description	Key

1	Without function	Without function	4
2	Lifting/Lowering chassis	Memory level	5
3	Normal level	Unloading level off switch	6
Home	Back to the main menu	Without function	Next

Functions

6.1.1 1-point control

SmartBoard - ECAS > Lifting/lowering chassis			
Key	Description	Description	Key

1	Without function	Without function	4
2	Lowering chassis	Lifting chassis	5
3	Without function	ECAS Stop	6
Home	Back to ECAS menu	Without function	Next

6.1.2 2-point control Drawbar trailer

SmartBoard - ECAS > Lifting/lowering chassis			
Key	Description	Description	Key

1	Control front	Control rear	4
2	Lowering chassis	Lifting chassis	5
3	Without function	ECAS Stop	6
Home	Back to ECAS menu	Next page	Next

Functions

6.1.3 2-point control Semitrailer

SmartBoard - ECAS > Lifting/lowering chassis

Key	Description	Description	Key
1	Control left	Control right	4
2	Lowering chassis	Lifting chassis	5
3	Without function	ECAS Stop	6
Home	Back to ECAS menu	Next page	Next



6.1.4 Normal level

SmartBoard - ECAS > Normal level

Key	Description	Description	Key
1	Select normal level 2	Select normal level 4	4
2	Select normal level 3	Without function	5
3	Without function	Without function	6
Home	Back to ECAS menu	Without function	Next



Functions

6.1.5 Memory level

SmartBoard - ECAS > Memory level

Key	Description	Description	Key
1	Without function	Without function	4
2	Memory level 1 - select / save (hold down)	Memory level 2 - select / save (hold down)	5
3	Without function	Without function	6
Home	Back to ECAS menu	Without function	Next

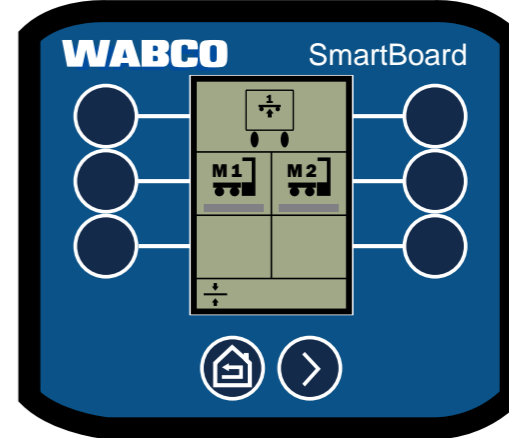

6.2 Axle load indicator

Display axle load and status (lifted/lowered).

SmartBoard - Axle load

Key	Description	Description	Key
1	Without function	Without function	4
2	Without function	Without function	5
3	Without function	Without function	6
Home	Back to the main menu	Without function	Next



Functions

6.3 Bounce Control

SmartBoard - Bounce Control

Key	Description	Description	Key
1	Without function	Without function	4
2	Without function	Without function	5
3	Activate/deactivate bounce control	Without function	6
Home	Back to the main menu	Without function	Next



6.4 Brake lining wear

Display brake lining status.

Brake lining wear OK

Wear threshold for brake lining reached

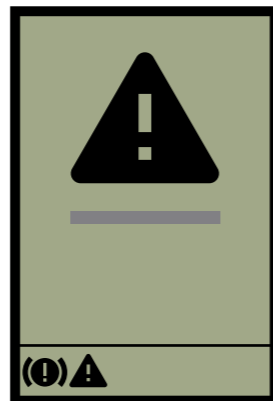
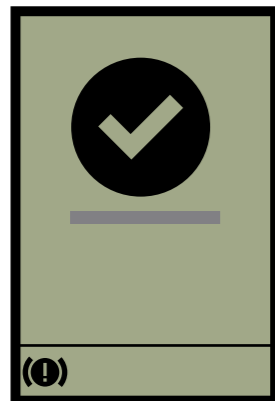

Functions

6.5 Release brakes

Temporarily release brakes.

SmartBoard - Release brake

Key	Description	Description	Key
1	Without function	Without function	4
2	Without function	Without function	5
3	Release brake (hold down)	Without function	6
Home	Back to the main menu	Without function	Next



6.6 Trailer length

Show trailer length.

SmartBoard - Trailer length

Key	Description	Description	Key
1	Without function	Without function	4
2	Without function	Without function	5
3	Without function	Without function	6
Home	Back to the main menu	Without function	Next



Functions

6.7 Diagnostic memory

Show current and saved error messages.

SmartBoard - Diagnostic memory			
Key	Description	Description	Key
1	Without function	Without function	4
2	Without function	Without function	5
3	Previous message	Next message	6
Home	Back to the main menu	Next message	Next



Figure	Description
System	System issuing the message (e.g. TEBS E) - appears at upper left in the display.
Warning lamp	Warning lamp displayed: Current message (the fault must be rectified). No warning lamp displayed: Not a current message (saved in ECU diagnostic memory).
Code	Message code.
Date	Date at the time of message output.
Time	Time of message output.
Occurrence	Odometer reading at time of message output.
Status	Current or saved message.

Functions

6.8 Electronic parking brake

i The electronic parking brake can be configured to be disabled temporarily or permanently. If the parking brake cannot be disabled permanently, the option does not appear in the menu.

Enable and (permanently) disable the electronic parking brake.

SmartBoard - Electronic parking brake			
Key	Description	Description	Key
1	Without function	Without function	4
2	Permanently disable	Without function	5
3	Disable	Enable	6
Home	Back to the main menu	Without function	Next



6.9 Lifting axle control

Manually lift/lower, OptiTurn™, use traction help and OptiLoad™, disable lifting axle.

SmartBoard - Lifting axle control			
Key	Description	Description	Key
1	Lifting axle control	OptiLoad™	4
2	OptiTurn™	Without function	5
3	Traction help	Without function	6
Home	Back to the main menu	Without function	Next



Functions

6.9.1 Lifting axle control

SmartBoard - Lifting axle control > Control lifting axle

Key	Description	Description	Key
1	Without function	Without function	4
2	Without function	Without function	5
3	Lift lifting axle	Lower lifting axle	6
Home	Back to lifting axle control	Without function	Next

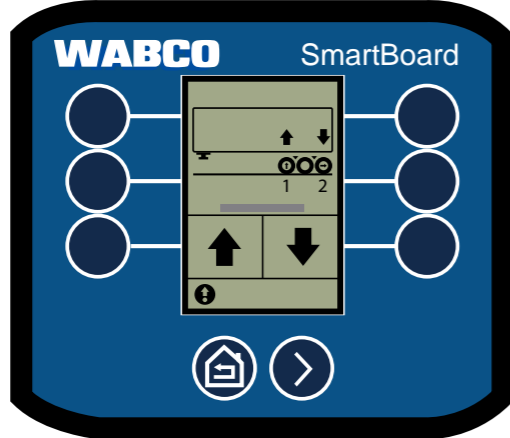

6.9.2 Disable lifting axle(s)

SmartBoard - Lifting axle control > Disable lifting axle

Key	Description	Description	Key
1	Without function	Without function	4
2	Without function	Without function	5
3	Enable/disable lifting axle 1	Enable/disable lifting axle 2	6
Home	Back to lifting axle control	Without function	Next



Functions

6.9.3 OptiTurn™

SmartBoard - Lifting axle control > OptiTurn™

Key	Description	Description	Key
1	Without function	Without function	4
2	Without function	Without function	5
3	Enable/disable	Options	6
Home	Back to lifting axle control	Without function	Next



OptiTurn™ options

SmartBoard - Lifting axle control > OptiTurn™ > Options

Key	Description	Description	Key
1	Enable/disable automatically	Without function	4
2	Without function	Without function	5
3	Without function	Without function	6
Home	Back to OptiTurn™	Without function	Next



Functions

6.9.4 Traction help

SmartBoard - Lifting axle control > Traction help

Key	Description	Description	Key
1	Without function	Without function	4
2	Without function	Without function	5
3	Enable/disable	Options	6
Home	Back to lifting axle control	Without function	Next



Traction help options

SmartBoard - Lifting axle control > Traction help > Options

Key	Description	Description	Key
1	Enable/disable automatically	Seasonal traction help	4
2	Show season period	Without function	5
3	Without function	Without function	6
Home	Back to lifting axle control	Without function	Next



Functions

6.9.5 OptiLoad™

SmartBoard - Lifting axle control > OptiLoad™

Key	Description	Description	Key
1	Without function	Without function	4
2	Without function	Without function	5
3	Enable/disable	Options	6
Home	Back to lifting axle control	Without function	Next



OptiLoad™ options

SmartBoard - Lifting axle control > OptiLoad™ > Options

Key	Description	Description	Key
1	Enable/disable automatically	Without function	4
2	Without function	Without function	5
3	Without function	Without function	6
Home	Back to OptiLoad™	Without function	Next



Functions

6.9.6 Odometer

i If the configured values of the tyre circumference and flywheel number do not match the values of the modulator, a "!" appears before "Odometer".

SmartBoard - Lifting axle control > Odometer

Key	Description	Description	Key
1	Without function	Without function	4
2	Without function	Without function	5
3	Without function	Reset odometer	6
Home	Back to the main menu	Without function	Next



6.10 SafeStart

Limit speed when loading/unloading a tipping or tank trailer.

SmartBoard - SafeStart

Key	Description	Description	Key
1	Without function	Without function	4
2	Without function	Without function	5
3	Enable/disable	Without function	6
Home	Back to the main menu	Without function	Next



Functions

6.11 Automatic steering axle

Enable or lock the automatic steering axle.

SmartBoard - Steering axle lock

Key	Description	Description	Key
1	Without function	Without function	4
2	Without function	Without function	5
3	Enable automatic steering axle	Lock automatic steering axle	6
Home	Back to the main menu	Without function	Next



6.12 Vehicle inclination

Show angle of inclination warning.

Vehicle inclination within tolerance range

Max. vehicle inclination exceeded

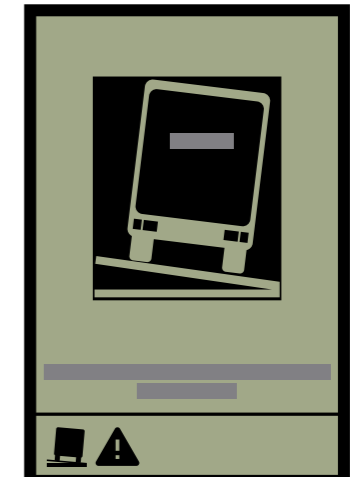
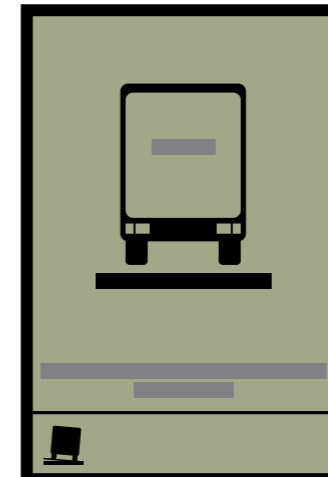

Functions

6.13 Work light control

SmartBoard - Work light control

Key	Description	Description	Key
1	Without function	Without function	4
2	Without function	Without function	5
3	Enable/disable work light	Without function	6
Home	Back to the main menu	Without function	Next



6.14 Road finisher brake

SmartBoard - Road finisher brake

Key	Description	Description	Key
1	Without function	Without function	4
2	Reduce braking pressure	Increase braking pressure	5
3	Enable/disable	Without function	6
Home	Back to the main menu	Without function	Next



6.15 OptiTire™

Show tyre pressures, reference pressures, tyre temperature, wheel IDs, battery status and signal strength.

- To change reference pressures and wheel IDs, see chapter "6.17.8 OptiTire™ functions", page 43.
- Press the *Next* key to display the various data.
- Press the *Home* key to return to the main menu.

Functions

6.16 Freely configurable GIO functions (GIO FCF)

In addition to the analogue and digital functions, it is also possible to store what are known as GIO function modules via the diagnosis. These are capable of processing internal signals (CAN bus, internal pressures, speeds) as well as external input variables (such as switch, pressure sensor, SmartBoard).

Output signals as well as internal functions such as saving events to the event recorder can be controlled according GIO function module programming. The function can therefore be used to implement small customer-specific applications.

Freely configurable digital function

Free programming by the manufacturer of a GIO digital input or output depending on speeds and times.

Freely configurable analogue function

Free programming by the manufacturer of a GIO analogue input or output depending on speeds and times.

With both analogue and digital functions, an Event (for example) can be stored or a GIO output switched as a function of a switch signal and the vehicle speed.

Parameter setting

The function is loaded into the diagnostic software using a *.FCF or *.ECU file.

i Please speak with your WABCO partner about parameters for the freely configurable functions. Only files created by WABCO can be loaded into the ECU.

Controlling GIO FCF with the SmartBoard

Control of the GIO functions can be configured in the diagnostic software so that they are operated either by a button or a rocker switch.

Button switch

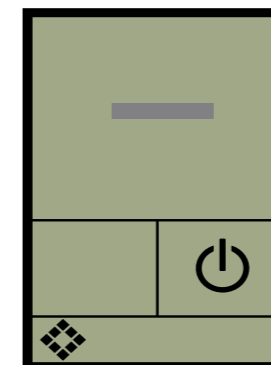

Rocker switch

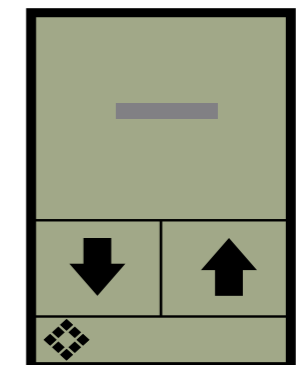

Functions

6.17 Settings

SmartBoard - Settings

Key	Description	Description	Key
1	Units	Brightness	4
2	Screen saver	Time / date	5
3	Axle load calibration	Start screen	6
Home	Back to the main menu	Next page	Next



SmartBoard - Settings > Page 2

Key	Description	Description	Key
1	Axle overload	Sort functions	4
2	Language	Reset to factory settings	5
3	CAN termination	Odometer settings	6
Home	Back to the main menu	Next page	Next



SmartBoard - Settings > Page 3

Key	Description	Description	Key
1	Immobilizer settings	Without function	4
2	OptiTire™ functions	Without function	5
3	Without function	Without function	6
Home	Back to the main menu	Next page	Next



Functions

6.17.1 Units

SmartBoard - Settings > Units

Key	Description	Description	Key
1	Without function	Without function	4
2	Up	Down	5
3	Save and back	Without function	6
Home	Back to settings	Without function	Next



6.17.2 Screen saver

When inactive, display the "Trailer Info" screen or an image you have created yourself ("Splash Screen").

i The SmartBoard diagnostic software is required to use a self-created image in the SmartBoard. You can find this at:

<https://www.am.wabco-auto.com/>

SmartBoard - Settings > Screen saver

Key	Description	Description	Key
1	Without function	Without function	4
2	Without function	Without function	5
3	Enable/disable	Set inactivity time	6
Home	Back to settings	Forward to "Select screen saver"	Next



Functions

Set inactivity time

The screen saver is launched on expiry of a specified inactivity time. The duration of the inactivity time is set in seconds.

SmartBoard - Settings > Screen saver

Key	Description	Description	Key
1	Without function	Without function	4
2	Reduce time	Increase time	5
3	Save and back	Without function	6
Home	Back to screen saver	Without function	Next



Splash screen

The SmartBoard can be configured so that a self-generated image is used as a screen saver instead of the "Trailer Info" screen.

SmartBoard - Settings > Screen saver

Key	Description	Description	Key
1	Without function	Without function	4
2	Without function	Without function	5
3	Enable/disable	Select screen saver	6
Home	Back to settings	Forward to "Set inactivity time"	Next



Functions

Select screen saver

Switch between "Trailer Info" and "Splash Screen".

SmartBoard - Settings > Screen saver page 2

Key	Description	Description	Key
1	Without function	Without function	4
2	Down	Up	5
3	Save and back	Without function	6
Home	Back to settings	Without function	Next



6.17.3 Axle load calibration

SmartBoard - Settings > Axle load calibration

Key	Description	Description	Key
1	Without function	Without function	4
2	Without function	Without function	5
3	Reset calibration	Start calibration	6
Home	Back to the main menu	Without function	Next



Functions

Run axle load calibration

Calibrate axle loads in empty, partially loaded and loaded state.

1. Select *Start calibration*.
2. Read and follow the instructions on the screen.
3. Press Next (key 6).
⇒ The screen for selecting the load status is displayed.

SmartBoard - Settings > Axle load calibration

Key	Description	Description	Key
1	Without function	Calibrate as loaded	4
2	Without function	Calibrate as partially loaded	5
3	Without function	Calibrate as empty	6
Home	Back to axle load calibration	Without function	Next



4. Select the load status you want to calibrate.
⇒ The screen for entering the measured value is displayed.

SmartBoard - Settings > Axle load calibration

Key	Description	Description	Key
1	Select left	Select right	4
2	Decrease value	Increase value	5
3	Save and back	Without function	6
Home	Back to axle load calibration	Without function	Next



Functions

Drawbar trailer

SmartBoard - Settings > Axle load calibration

Key	Description	Description	Key
1	Select front axle(s)	Select rear axle(s)	4
2	Decrease value	Increase value	5
3	Save and back	Without function	6
Home	Back to axle load calibration	Without function	Next



6.17.4 Brightness

SmartBoard - Settings > Brightness

Key	Description	Description	Key
1	Without function	Without function	4
2	Decrease brightness	Increase brightness	5
3	Save and back	Without function	6
Home	Back to settings	Without function	Next

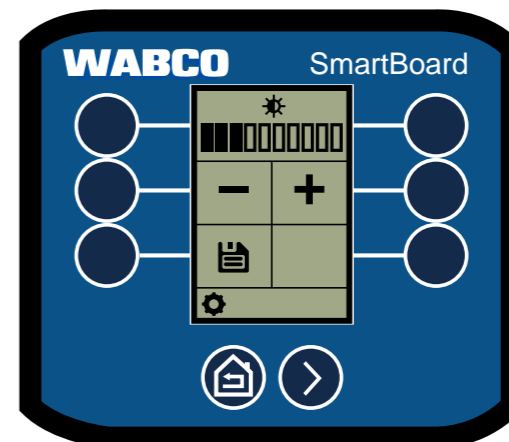

Functions

6.17.5 Time / date

SmartBoard - Settings > Time/Date

Key	Description	Description	Key
1	Without function	Without function	4
2	Set time	Set date	5
3	Select time zone	Without function	6
Home	Back to settings	Without function	Next



6.17.6 Start screen

Select the screen to be displayed when the SmartBoard is first started.

SmartBoard - Settings > Start screen

Key	Description	Description	Key
1	Without function	Without function	4
2	Down	Up	5
3	Save and back	Without function	6
Home	Back to settings	Without function	Next



Functions

6.17.7 Axle overload

Set warning messages for axle overload according to the number of axles.

SmartBoard - Settings > Axle overload

Key	Description	Description	Key
1	Without function	Without function	4
2	Without function	Without function	5
3	Select number of axles	Set max. mass	6
Home	Back to settings	Without function	Next



6.17.8 OptiTire™ functions

Set reference pressure by axle or by pair (with twin tyres) and change wheel ID.

Set reference pressure

SmartBoard - Settings > OptiTire™

Key	Description	Description	Key
1	Without function	Without function	4
2	Without function	Without function	5
3	Change reference pressure	Switch axles / tyre pair (twin tyre)	6
Home	Back to settings	Next page	Next



Functions

Change wheel ID

i With sensors with an 8-digit ID, the first two numbers must be set to 0.

SmartBoard - Settings > OptiTire™

Key	Description	Description	Key
1	Without function	Without function	4
2	Without function	Without function	5
3	Change wheel ID	Select wheel	6
Home	Back to settings	Without function	Next



Functions

6.17.9 Reorder functions in the main menu

i The factory settings specify that frequently used functions are automatically arranged in the main menu. This function can be disabled in the settings.

1. Press the key next to the function whose position you want to change.
2. Press the key next to the function in the place where you want to put the selected function.
3. Press the *Home* key to save or cancel the allocation.
 - ⇒ The functions have been rearranged.

SmartBoard - Settings > Arrange Functions

Key	Description	Description	Key
1	Select function	Select function	4
2	Select function	Select function	5
3	Select function	Select function	6
Home	Save and back	Next page	Next



Functions

6.17.10 Odometer settings

Set wheel circumference and number of flywheel teeth.

SmartBoard - Settings > Odometer

Key	Description	Description	Key
1	Without function	Without function	4
2	Down	Up	5
3	Edit selection	Transfer parameter from modulator	6
Home	Back to settings	Without function	Next



Change tyre circumference

SmartBoard - Settings > Odometer > Tyre circumference

Key	Description	Description	Key
1	Without function	Without function	4
2	Reduce number	Increase number	5
3	Save and back	Transfer parameter from modulator	6
Home	Back to odometer	Switch position	Next



Functions

Change flywheel number

SmartBoard - Settings > Odometer > Flywheel number

Key	Description	Description	Key
1	Without function	Without function	4
2	Reduce number	Increase number	5
3	Save and back	Transfer parameter from modulator	6
Home	Back to odometer	Switch position	Next



6.17.11 CAN termination

Enable/disable the SmartBoard CAN resistance.

SmartBoard - Settings > CAN termination

Key	Description	Description	Key
1	Without function	Without function	4
2	Without function	Without function	5
3	Enable/disable	Without function	6
Home	Back to settings	Without function	Next



Functions

6.17.12 Language

SmartBoard - Settings > Language

Key	Description	Description	Key
1	Without function	Without function	4
2	Down	Up	5
3	Save and back	Without function	6
Home	Back to settings	Without function	Next



6.17.13 Change immobilizer PIN/PUK

Set new PIN by entering the current PIN or PUK.

SmartBoard - Settings > Change PIN/PUK

Key	Description	Description	Key
1	Without function	Without function	4
2	Down	Up	5
3	Edit	Without function	6
Home	Back to info	Without function	Next



Functions

6.17.14 Reset to factory settings

SmartBoard - Settings > Factory Settings

Key	Description	Description	Key
1	Without function	Without function	4
2	Without function	Without function	5
3	Reset	Without function	6
Home	Back to settings	Without function	Next



6.18 Info

View various sets of system information.

SmartBoard - Info

Key	Description	Description	Key
1	Trailer info	Temperature	4
2	System info	"Terminal 30" function	5
3	ODR data	Without function	6
Home	Back to the main menu	Without function	Next



Functions

6.18.1 Trailer info

Display an overview of the trailer configuration.

SmartBoard - Info > Trailer info			
Key	Description	Description	Key
1	Without function	Without function	4
2	Without function	Without function	5
3	Without function	Without function	6
Home	Back to info	Without function	Next



6.18.2 System info

Display information on the installed systems.

SmartBoard - Info > System info			
Key	Description	Description	Key
1	Without function	Without function	4
2	Without function	Without function	5
3	Without function	Without function	6
Home	Back to info	Show next ECU	Next



Functions

6.18.3 ODR data

Display ODR data (Operating Data Recorder).

SmartBoard - Info > ODR data			
Key	Description	Description	Key
1	Without function	Without function	4
2	Without function	Without function	5
3	Without function	Without function	6
Home	Back to info	Next page	Next



6.18.4 Operating temperature

Display operating temperature.

SmartBoard - Info > Temperature			
Key	Description	Description	Key
1	Without function	Without function	4
2	Without function	Without function	5
3	Without function	Without function	6
Home	Back to info	Without function	Next



Functions

6.18.5 Terminal 30 (tl. 30)

Display the supply voltage for the trailer via the towing vehicle battery.

SmartBoard - Info > TI. 30

Key	Description	Description	Key
1	Without function	Without function	4
2	Without function	Without function	5
3	Without function	Without function	6
Home	Back to info	Without function	Next



6.19 Immobilizer

Enable/disable the immobilizer; manage PIN and PUK.

i If the Personal Identification Number (PIN) is entered incorrectly three times, the next entry is delayed by a waiting period. The waiting time can be interrupted by entering the Personal Unblocking Key (PUK).

Activate/deactivate immobilizer

SmartBoard - Info > Immobilizer

Key	Description	Description	Key
1	Without function	Without function	4
2	Reduce number	Increase number	5
3	Enable/disable	Without function	6
Home	Back to info	Select next number	Next



Functions

6.20 Emergency release (immobilizer)

The emergency release allows the brake to be released up to 3 times, even when the immobilizer is enabled. As soon as the vehicle stops the immobilizer is activated again. The remaining releases are displayed. The function is active while the immobilizer is disabled.

SmartBoard - Emergency release

Key	Description	Description	Key
1	Without function	Without function	4
2	Without function	Without function	5
3	Confirm emergency release	Without function	6
Home	Back to the main menu	Without function	Next



7 Maintenance and care

7.1 Maintenance

The SmartBoard 446 192 211 0 is maintenance-free. The SmartBoard 446 192 210 0 battery must be replaced at an interval of approx. six years.

7.2 Replacement part sets

The following replacement part sets are available for the SmartBoard:

Description	WABCO part number
Replacement battery	446 192 930 2
Brackets	446 192 931 2

7.3 Changing the battery

The SmartBoard 446 192 210 0 contains a special battery that supplies power to the unit in the event of an interruption in the trucks/trailer power supply. Only change the battery in a dry and clean environment. The replacement battery is supplied with two replacement screws that must be used when changing the battery.

1. If necessary, remove the SmartBoard from the vehicle.

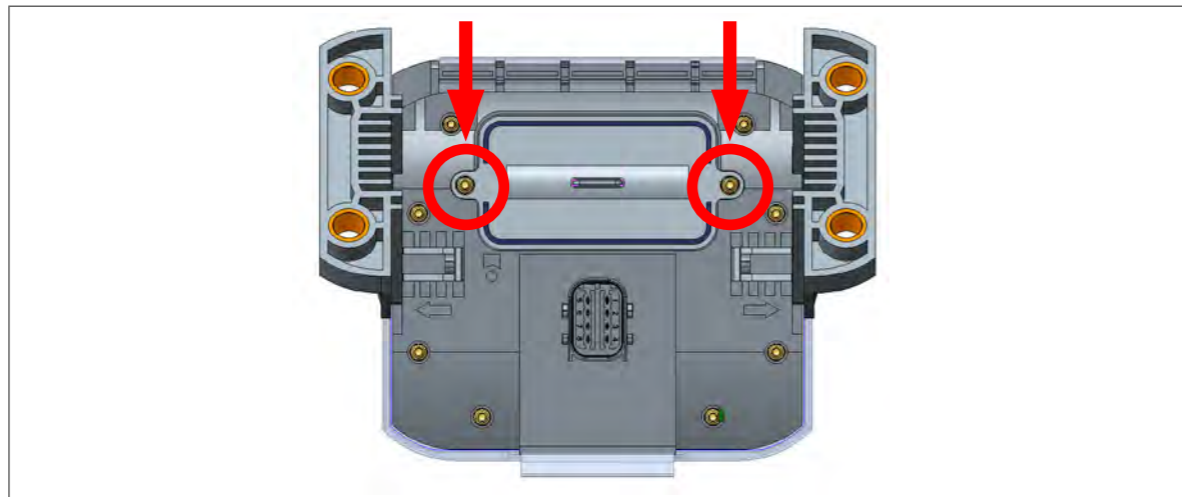

2. Unscrew the two Torx® screws on the battery cover.

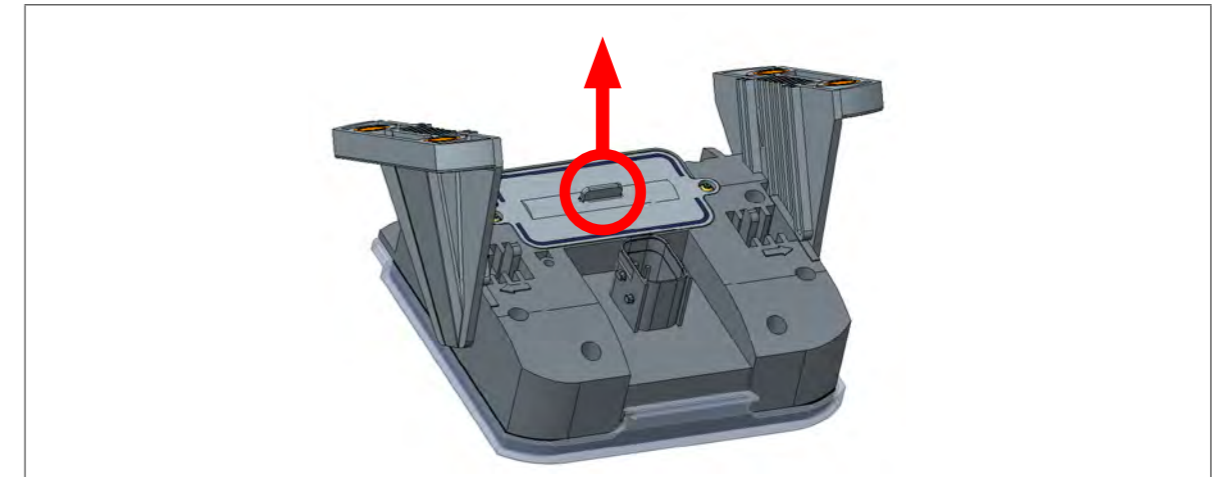

3. Remove the battery cover with a pair of flat nose pliers.
4. Carefully unplug the battery (avoid sideways movements).

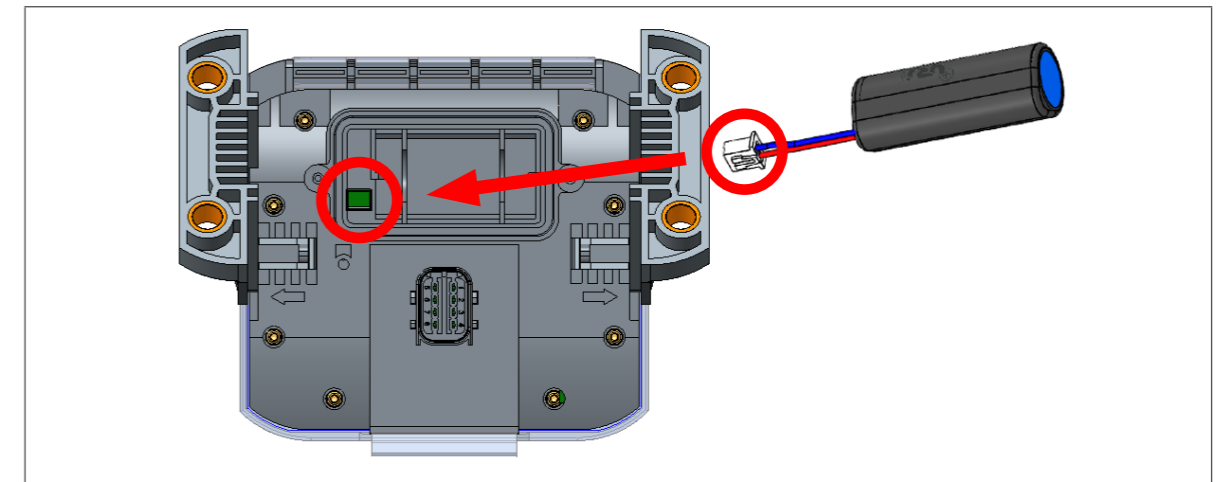

5. Push the replacement battery plug into the slot provided for it with the correct polarity and insert the replacement battery.
6. Insert the battery cover.
7. Insert the replacement screws.
8. Tighten the replacement screws (max. torque 0.6 Nm ± 0.1 Nm).
⇒ The battery change is complete.

7.4 Cleaning

Use only a damp cloth to clean the SmartBoard. Never use cleaning agents. Detergents and other chemicals can damage the display and the keyboard and must never come into contact with the SmartBoard.

8 Storage

Do not store the SmartBoard in a location where there is the possibility of it being exposed to water, salt or oil.

Do not store the SmartBoard in a location where the air contains dangerous gases such as hydrogen sulphide, sulphuric acid, nitrous acid, chlorine or ammonia.

Do not store the SmartBoard in a location where there is the possibility of it being exposed to direct sunlight, ultraviolet rays, ozone or radiation.

Operate the SmartBoard every two years to maintain the electrolytic capacitors on the inside. When doing so, only connect the SmartBoard to the power supply for half an hour.

Only store the SmartBoard for the duration and at the temperatures specified in the following table, to prevent damage.

Storage temperatures		
SmartBoard	Temperature (°C)	Duration (years)
446 192 210 0	-20 – 45	1
446 192 211 0	-20 – 50	2
	5 – 35	15

9 Disposal

- The final and professional decommissioning and disposal of the product must be carried out in accordance with the applicable legal regulations of the user country. In particular, the regulations for the disposal of batteries, equipment and the electrical system must be observed.
- Electrical appliances must be collected separately from household or commercial waste and recycled or disposed of in accordance with regulations.
- If applicable, take the old device to the company's internal disposal department, which will then forward it to specialist companies (specialist disposal companies).
- In principle, it is also possible to return the old device to the manufacturer. For this purpose, contact the manufacturer's customer service. Any special agreements must be observed.
- Electrical and electronic equipment must be collected separately from unsorted municipal waste and recycled or disposed of properly, because harmful substances can cause lasting damage to health and the environment if disposed of improperly.
- Detailed information can be obtained from specialist waste management companies or the responsible authorities.
- The packaging must be disposed of separately. Paper, cardboard and plastics must be recycled.

10 Fault codes

Example: SmartBoard display
Code 001 07

1. Numerical block
Component
001 – wheel sensor a

2. Numerical block
Type of fault
07 – driving route too large

Code	Message
Component: TEBS E	
001	Wheel sensor a
002	Wheel sensor b
003	Wheel sensor c
004	Wheel sensor d
005	Wheel sensor e
006	Wheel sensor f
007	EBS (ABS) relay valve / solenoid valve control
009	Trailer modulator / solenoid valve control
010	Trailer modulator / solenoid control
058	EBS relay valve / redundancy
059	EBS relay valve / pressure sensor
061	Trailer modulator / redundancy
062	Trailer modulator / pressure sensors
069	Axle load sensor, internal
075	Wear sensor
076	Error when selecting the nominal value / redundant braking
077	Nominal pressure sensor, internal
078	Nominal pressure sensor, external
080	Demand pressure sensor, internal
081	Braking pressure sensor (axle c-d)
082	Switch 1 for trailer length
083	Switch 2 for trailer length
084	Switch 3 for trailer length
085	Switch 4 for trailer length
086	Switch for overload indication
088	Lateral acceleration sensor
089	Proximity switch

Code	Message
090	Freely configurable function 8
091	Freely configurable function 7
092	Freely configurable function 6
093	Freely configurable function 5
094	Freely configurable function 4
095	Freely configurable function 3
096	Freely configurable function 2
097	Freely configurable function 1
099	IN/OUT port
100	GIO - freely configurable analogue function
101	GIO - freely configurable digital function
102	Slot GIO5
103	Slot GIO4
104	Slot GIO3
105	Slot GIO2
106	Slot GIO1
107	Slot GIO6
108	Slot GIO7
109	ABS sensor / memory bit
110	Slot Subsystems
111	Axle relaxation switch
112	Automatic lowering of lifting axle switch
113	SmartBoard
114	Diagnosis power supply
115	Telematics unit
116	OptiTire™
117	ECAS Remote Control Unit / Box
118	Axle load sensor, external (axle c-d)
119	Axle load sensor, external (axle e-f)
120	Distance sensor axle load (axle c-d)
121	Distance sensor axle load (axle e-f)

Code	Message
122	Freely programmable function 3
123	Freely programmable function 2
124	Freely programmable function 1
125	Unloading level switch
126	Output speed signal
127	Distance sensor 2 (axle e-f)
128	Distance sensor 1 (axle c-d)
129	ECAS valve block
130	Output steady positive voltage 2
131	Output steady positive voltage 1
132	Output RSS active signal
133	Output ABS active signal
134	Road finisher brake
135	Not used
136	LIN bus
137	Speed switch 2 (ISS 2)
138	Speed switch 1 (ISS 1) for manoeuvring assistance
139	Residual pressure maintenance valve
140	Residual pressure maintenance valve for traction help
141	Lifting axle valve 2
142	Lifting axle valve 1
143	Pneumatic control line
144	Supply pressure sensor
145	External electronic air suspension module
146	External ECAS
148	Internal ECAS / calibration
156	Not used
157	Normal level 2 switch
158	Up switch
159	Down switch
160	Brake release function
163	Axle load calibration
164	Not used
165	Trailer length proximity switch 1
167	Output steering axle lock

Fault codes

Code	Message	Code	Message
168	Switch output steering axle lock	211	Door locking system
169	Immobilizer PIN invalid	212	Lifting axle off switch
170	Output tilt warning	213	Monitoring system rear switch
178	Immobilizer valve	214	Trailer length proximity switch 2
179	Buzzer Immobilizer	215	Trailer length proximity switch 3
180	Demand pressure on CAN router/repeater	216	Trailer length proximity switch 4
181	CAN router/repeater power supply local system	217	Input switch ECAS ramp height control
182	CAN router/repeater power supply to the next system	220	Data link towing vehicle / trailer
183	CAN router/repeater to the local system	250	Not used
184	CAN router/repeater to the next system	251	Power supply
185	ECAS deactivation switch	253	Parameter setting
186	Normal level 4 switch	254	Trailer modulator
187	Forklift control switch	OptiTire™ components	
188	Second axle load sensor, external (axle c-d)	639	CAN (short-circuit / bus off)
189	SafeStart	927	Warning lamp 2 (optional / pin 4)
190	SafeStart pressure sensor	928	Warning lamp 1 (standard / pin 2)
191	SafeStart warning lamp	929	Tyre data cannot be analysed
192	Emergency brake light	1121	Data on the CAN data bus
193	Green warning lamp	3011...	Pressure in tyre
194	Brake temperature	3054	
195	eTASC rear axle	3111...	Leakage in tyre and valve
196	eTASC front axle	3154	
197	ECAS monoblock 2	3410...	Tyre Pressure Deviation
198	ECAS front axle valve	3500	
199	Driving level limitation switch	Type of fault	
200	GIO service indication	00	Value too high
201	Shared buzzer	01	Value too low
202	Shared warning lamp	02	Data is irregular or incorrect
203	Service mode	03	Overvoltage / short-circuit to 24 V
204	GIO operating hours counter warning lamp	04	Undervoltage / short-circuit to ground
205	Output overload indication	05	Break in supply cable
206	Output overload indication 3rd modulator	06	Current too high or circuit grounded
207	Electronic parking brake switch	07	Distance too great
208	Spring brake valve	08	Slip
209	2nd switch	09	Signal failure
210	Electronic parking brake valve	10	Jump up / jump down
		11/12	See failure note

Electronic Extension Module fault codes

11 Electronic Extension Module fault codes

Code in SmartBoard	Diagnostic Code	Description
1552-03	2483503	The component or the cable on analogue input 1 (GIO14) has a short-circuit to 24 V.
1552-04	2483604	The component or the cable on analogue input 1 (GIO14) has a short-circuit to ground.
1568-03	2509103	The component or the cable on analogue input 2 (GIO13) has a short-circuit to 24 V.
1568-04	2509204	The component or the cable on analogue input 2 (GIO13) has a short-circuit to ground.
1632-03	2611503	The component or the cable on plug-connector GIO14, pin 1, has a short-circuit to 24 V.
1632-04	2611604	The component or the cable on plug-connector GIO14, pin 1, has a short-circuit to ground.
1632-05	2611705	The component or the cable at plug-connector GIO14, pin 1, is not connected.
1632-11	2612311	A component for which there are no parameter settings was detected at slot GIO14, pin 1.
1648-03	2637103	The component or the cable on plug-connector GIO16, pin 1, has a short-circuit to 24 V. The fault can also occur in a system with battery supply (TEBS In/Out on GIO16 connected), then ignore.
1648-04	2637204	The component or the cable on plug-connector GIO16, pin 1, has a short-circuit to ground.
1648-05	2637305	The component or the cable at plug-connector GIO16, pin 1, is not connected.
1648-11	2637911	A component for which there are no parameter settings was detected at slot GIO16, pin 1.
1664-03	2662703	The component or the cable on plug-connector GIO16, pin 4, has a short-circuit to 24 V.
1664-04	2662804	The component or the cable on plug-connector GIO16, pin 4, has a short-circuit to ground.
1664-05	2662905	The component or the cable at plug-connector GIO16, pin 4, is not connected.
1664-11	2663511	A component for which there are no parameter settings was detected at slot GIO16, pin 4.
1680-03	2688303	The component or the cable on plug-connector GIO15, pin 1, has a short-circuit to 24 V.
1680-04	2688404	The component or the cable on plug-connector GIO15, pin 1, has a short-circuit to ground.
1680-05	2688505	The component or the cable on plug-connector GIO15, pin 1, has a short-circuit to ground.
1680-11	2689111	A component for which there are no parameter settings was detected at slot GIO15, pin 1.
1696-03	2713903	The component or the cable on plug-connector GIO13, pin 4, has a short-circuit to 24 V.
1696-04	2714004	The component or the cable on plug-connector GIO13, pin 4, has a short-circuit to ground.
1696-05	2714105	The component or the cable at plug-connector GIO13, pin 4, is not connected.
1696-11	2714711	A component for which there are no parameter settings was detected at slot GIO13, pin 4.

Electronic Extension Module fault codes

Code in SmartBoard	Diagnostic Code	Description
1712-03	2739503	The component or the cable on plug-connector GIO15, pin 3, has a short-circuit to 24 V.
1712-04	2739604	The component or the cable on plug-connector GIO15, pin 3, has a short-circuit to ground.
1712-05	2739705	The component or the cable at plug-connector GIO15, pin 3, is not connected.
1712-11	2740311	A component for which there are no parameter settings was detected at slot GIO15, pin 3.
1728-03	2765103	The component or the cable on plug-connector GIO15, pin 4, has a short-circuit to 24 V.
1728-04	2765204	The component or the cable on plug-connector GIO15, pin 4, has a short-circuit to ground.
1728-05	2765305	The component or the cable at plug-connector GIO15, pin 4, is not connected.
1728-11	2765911	A component for which there are no parameter settings was detected at slot GIO15, pin 4.
1744-03	2790703	The component or the cable on plug-connector GIO13, pin 1, has a short-circuit to 24 V.
1744-04	2790804	The component or the cable on plug-connector GIO13, pin 1, has a short-circuit to ground.
1744-05	2790905	The component or the cable at plug-connector GIO13, pin 1, is not connected.
1744-11	2791511	A component for which there are no parameter settings was detected at slot GIO13, pin 1.
1760-03	2816303	The component or the cable on plug-connector Subsystems pin 5 (tl. 15) has a short-circuit to 24 V.
1760-04	2816404	The component or the cable on plug-connector Subsystems pin 5 (tl. 15) has a short-circuit to ground.
1760-05	2816505	No components are connected on the plug-connector Subsystems pin 5 (tl. 15).
1760-11	2817111	A component for which there are no parameter settings was detected on slot Subsystems pin 5 (tl. 15).
1905-03	3048303	The supply voltage to the Electronic Extension Module is below 9 V.
1905-04	3048404	The supply voltage to the Electronic Extension Module is above 30 V.
1920-02	3072202	No echo signal received from ultrasonic sensor 1 (left). Sensor or sensor cable defective or not plugged in.
1920-03	3072303	The cable to the ultrasonic sensor 1 (left) cable has a short-circuit to 24 V.
1920-04	3072404	The cable to the ultrasonic sensor 1 (left) cable has a short-circuit to ground.
1921-03	3073903	The cable for the power supply for the ultrasonic sensor(s) on the GIO17 cable has a short-circuit to 24 V.
1921-04	3074004	The cable for the power supply for the ultrasonic sensor(s) on the GIO17 or GIO18 has a short-circuit to ground.
1936-02	3097802	No echo signal received from ultrasonic sensor 2 (right). Sensor or sensor cable defective or not plugged in.
1936-03	3097903	The cable to ultrasonic sensor 2 (right) cable has a short-circuit to 24 V.
1936-04	3098004	The cable to ultrasonic sensor 2 (right) cable has a short-circuit to ground.
1937-03	3099503	The cable for the power supply for the ultrasonic sensor(s) on the GIO18 cable has a short-circuit to 24 V.

Electronic Extension Module fault codes

Code in SmartBoard	Diagnostic Code	Description
1937-04	3099604	The cable for the power supply for the ultrasonic sensor(s) on the GIO17 or GIO18 cable has a short-circuit to ground.
1952-12	3124412	TailGUARD™ function cancelled because of a sensor error. This error can also occur with heavy parasitic noises.
1968-12	3150012	TailGUARD™ function cancelled because of a sensor error in the main level. This error can also occur with heavy parasitic noises.
1968-14	3150214	TailGUARD™ was deactivated while reversing.
1969-12	3151612	TailGUARD™ function cancelled because of a sensor error in the expanded level. This error can also occur with heavy parasitic noises.
1984-12	3175612	TailGUARD™ function cancelled because of a fault in the Trailer EBS.
1985-12	3177212	General termination of the TailGUARD™ function due to excessive reversing speed or faults in the TailGUARD™ components during operation. Note the additional information ("Info" button).
2032-02	3251402	Implausible signal from distance sensor 2.
2032-03	3251503	The cable to distance sensor 2 has a short-circuit to 24 V.
2032-04	3251604	The cable to distance sensor 2 has a short-circuit to ground.
2032-05	3251705	The cable to distance sensor 2 is not connected or is defective. This fault can also occur in combination with the fault "Power supply too low", then ignore.
2032-11	3252311	A component for which there are no parameter settings was detected at slot GIO13, pin 4.
2048-02	3277002	Implausible signal from distance sensor 1.
2048-03	3277103	The cable to distance sensor 1 has a short-circuit to 24 V.
2048-04	3277204	The cable to distance sensor 1 has a short-circuit to ground.
2048-05	3277305	The cable to distance sensor 1 is not connected or is defective.
2048-11	3277911	A component for which there are no parameter settings was detected at slot GIO14, pin 4.
2080-03	3328303	The LIN bus to the ultrasonic sensors (GIO17 or GIO18) was interrupted by excessive voltage. Check the sensor cable.
2080-04	3328404	The LIN bus to the ultrasonic sensors (GIO17 or GIO18) has a short to ground. Check the sensor cable.
2080-05	3328505	No sensor is connected on the line of the LIN bus to the ultrasonic sensors (GIO17 or GIO18).
2080-09	3328909	The LIN bus to the ultrasonic sensors is having communication problems. Switch the ignition off and on again.
2081-03	3329903	The LIN bus to the ultrasonic sensors (GIO17 or GIO18) was interrupted by excessive voltage. Check the sensor cable.
2081-04	3330004	The LIN bus to the ultrasonic sensors (GIO17 or GIO18) has a short to ground. Check the sensor cable.
2081-13	3330913	The ultrasonic sensors are not configured.
2097-12	3356412	Ultrasonic sensor 1 (main level left) has an internal error. If the fault occurs frequently, replace the sensor.
2098-00	3356800	Ultrasonic sensor 1 (main level left) has an internal error. If the fault occurs frequently, replace the sensor.
2099-00	3358400	Ultrasonic sensor 1 (main level left) has an internal error. If the fault occurs frequently, replace the sensor.
2100-12	3361212	Ultrasonic sensor 1 (main level left) has an internal error. If the fault occurs frequently, replace the sensor.
2101-12	3362812	Ultrasonic sensor 1 (main level left) has an internal error. If the fault occurs frequently, replace the sensor.

Electronic Extension Module fault codes

Code in SmartBoard	Diagnostic Code	Description
2102-12	3364412	Ultrasonic sensor 1 (main level left) has a sensor membrane error. Make sure that the sensor membrane is clean and the sensor has a free view. If the error continues to occur, replace the sensor.
2103-05	3365305	The cable to the ultrasonic sensor 1 (main level left) was interrupted or a new ultrasonic sensor has not been learned yet. If the fault occurs during TailGUARD™ start-up, ignore the fault and repeat the start-up procedures.
2113-12	3382012	Ultrasonic sensor 2 (main level right) has an internal error. If the fault occurs frequently, replace the sensor.
2114-00	3382400	Ultrasonic sensor 2 (main level right) has an internal error. If the fault occurs frequently, replace the sensor.
2115-00	3384000	Ultrasonic sensor 2 (main level right) has an internal error. If the fault occurs frequently, replace the sensor.
2116-12	3386812	Ultrasonic sensor 2 (main level right) has an internal error. If the fault occurs frequently, replace the sensor.
2117-12	3388412	Ultrasonic sensor 2 (main level right) has an internal error. If the fault occurs frequently, replace the sensor.
2118-12	3390012	Ultrasonic sensor 2 (main level right) has a sensor membrane error. Make sure that the sensor membrane is clean and the sensor has a free view. If the error continues to occur, replace the sensor.
2119-05	3390905	The cable to ultrasonic sensor 2 (main level right) is interrupted or a new ultrasonic sensor has not been learned yet. If the fault occurs during TailGUARD™ start-up, ignore the fault and repeat the start-up procedures.
2129-12	3407612	Ultrasonic sensor 3 (main level middle) has an internal error. If the fault occurs frequently, replace the sensor.
2130-00	3408000	Ultrasonic sensor 3 (main level middle) has an internal error. If the fault occurs frequently, replace the sensor.
2131-00	3409600	Ultrasonic sensor 3 (main level middle) has an internal error. If the fault occurs frequently, replace the sensor.
2132-12	3412412	Ultrasonic sensor 3 (main level middle) has an internal error. If the fault occurs frequently, replace the sensor.
2133-12	3414012	Ultrasonic sensor 3 (main level middle) has an internal error. If the fault occurs frequently, replace the sensor.
2134-12	3415612	Ultrasonic sensor 3 (main level middle) has a sensor membrane error. Make sure that the sensor membrane is clean and the sensor has a free view. If the error continues to occur, replace the sensor.
2135-05	3416505	The cable to ultrasonic sensor 3 (main level middle) is interrupted or a new ultrasonic sensor has not been learned yet. If the fault occurs during TailGUARD™ start-up, ignore the fault and repeat the start-up procedures.
2145-12	3433212	Ultrasonic sensor 4 (additional level left) has an internal error. If the fault occurs frequently, replace the sensor.
2146-00	3433600	Ultrasonic sensor 4 (additional level left) has an internal error. If the fault occurs frequently, replace the sensor.
2147-00	3435200	Ultrasonic sensor 4 (additional level left) has an internal error. If the fault occurs frequently, replace the sensor.
2148-12	3438012	Ultrasonic sensor 4 (additional level left) has an internal error. If the fault occurs frequently, replace the sensor.
2149-12	3439612	Ultrasonic sensor 4 (additional level left) has an internal error. If the fault occurs frequently, replace the sensor.

Electronic Extension Module fault codes

Code in SmartBoard	Diagnostic Code	Description
2150-12	3441212	Ultrasonic sensor 4 (additional level left) has a sensor membrane error. Make sure that the sensor membrane is clean and the sensor has a free view. If the error continues to occur, replace the sensor.
2151-05	3442105	The cable to ultrasonic sensor 4 (additional level left) is interrupted or a new ultrasonic sensor has not been learned yet. If the fault occurs during TailGUARD™ start-up, ignore the fault and repeat the start-up procedures.
2161-12	3458812	Ultrasonic sensor 5 (additional level right) has an internal error. If the fault occurs frequently, replace the sensor.
2162-00	3459200	Ultrasonic sensor 5 (additional level right) has an internal error. If the fault occurs frequently, replace the sensor.
2163-00	3460800	Ultrasonic sensor 5 (additional level right) has an internal error. If the fault occurs frequently, replace the sensor.
2164-12	3463612	Ultrasonic sensor 5 (additional level right) has an internal error. If the fault occurs frequently, replace the sensor.
2165-12	3465212	Ultrasonic sensor 5 (additional level right) has an internal error. If the fault occurs frequently, replace the sensor.
2166-12	3466812	Ultrasonic sensor 5 (additional level right) has a sensor membrane error. Make sure that the sensor membrane is clean and the sensor has a free view. If the error continues to occur, replace the sensor.
2167-05	3467705	The cable to ultrasonic sensor 5 (additional level right) is interrupted or a new ultrasonic sensor has not been learned yet. If the fault occurs during TailGUARD™ start-up, ignore the fault and repeat the start-up procedures.
2177-12	3484412	Ultrasonic sensor 6 (additional level middle) has an internal error. If the fault occurs frequently, replace the sensor.
2178-00	3484800	Ultrasonic sensor 6 (additional level middle) has an internal error. If the fault occurs frequently, replace the sensor.
2179-00	3486400	Ultrasonic sensor 6 (additional level middle) has an internal error. If the fault occurs frequently, replace the sensor.
2180-12	3489212	Ultrasonic sensor 6 (additional level middle) has an internal error. If the fault occurs frequently, replace the sensor.
2181-12	3490812	Ultrasonic sensor 6 (additional level middle) has an internal error. If the fault occurs frequently, replace the sensor.
2182-12	3492412	Ultrasonic sensor 6 (additional level right) has a sensor membrane error. Make sure that the sensor membrane is clean and the sensor has a free view. If the error continues to occur, replace the sensor.
2183-05	3493305	The cable to ultrasonic sensor 6 (additional level middle) is interrupted or a new ultrasonic sensor has not been learned yet. If the fault occurs during TailGUARD™ start-up, ignore the fault and repeat the start-up procedures.
2192-03	3507503	The cable to the trip recorder speed signal has a short-circuit to supply voltage.
2208-02	3533002	The speed signal is invalid. Move the vehicle. Should the fault persist, check the cabling of the speed signal.
2209-10	3535410	The speed signal is invalid. Switch the ignition off and on again and move the vehicle. Should the fault persist, check the cabling of the speed signal.
2224-03	3558703	Brake valve 1 has a short-circuit to supply voltage. Check the cabling.

Electronic Extension Module fault codes

Code in SmartBoard	Diagnostic Code	Description
2224-04	3558804	Brake valve 1 has a short-circuit to ground. Check the cabling.
2224-05	3558905	Brake valve 1 is not connected. Check the cabling.
2224-12	3559612	Brake valve 1 possibly has a leak or does not vent the brake line.
2225-03	3560303	Brake valve 2 has a short-circuit to supply voltage. Check the cabling.
2225-04	3560404	Brake valve 2 has a short-circuit to ground. Check the cabling.
2225-05	3560505	Brake valve 2 is not connected. Check the cabling.
2225-12	3561212	Brake valve 2 possibly has a leak or does not vent the brake line.
2243-11	3589911	Internal fault, the relay for the position lamps has a fault.
2257-12	3612412	Ultrasonic sensor 1 (GIO16) has an internal fault. If the fault occurs frequently, replace the sensor.
2260-12	3617212	Ultrasonic sensor 1 (GIO16) has an internal fault. If the fault occurs frequently, replace the sensor.
2261-12	3618812	Ultrasonic sensor 1 (GIO16) has an internal fault. If the fault occurs frequently, replace the sensor.
2262-12	3620412	Ultrasonic sensor 1 (GIO16) has a sensor membrane fault. Make sure that the sensor membrane is clean and the sensor has a free view. If the error continues to occur, replace the sensor.
2263-12	3622012	The cable to the ultrasonic sensor 1 (GIO16) was interrupted or a new ultrasonic sensor has not been learned yet. If the fault occurs during TailGUARD™ start-up, ignore the fault and repeat the start-up procedures.
2273-12	3638012	Ultrasonic sensor 2 (GIO16) has an internal fault. If the fault occurs frequently, replace the sensor.
2276-12	3642812	Ultrasonic sensor 2 (GIO16) has an internal fault. If the fault occurs frequently, replace the sensor.
2277-12	3644412	Ultrasonic sensor 2 (GIO16) has an internal fault. If the fault occurs frequently, replace the sensor.
2278-12	3646012	Ultrasonic sensor 2 (GIO16) has a sensor membrane fault. Make sure that the sensor membrane is clean and the sensor has a free view. If the error continues to occur, replace the sensor.
2279-12	3647612	The cable to the ultrasonic sensor 2 (GIO16) was interrupted or a new ultrasonic sensor has not been learned yet. If the fault occurs during TailGUARD™ start-up, ignore the fault and repeat the start-up procedures.
2289-12	3663612	Ultrasonic sensor 3 (GIO16) has an internal fault. If the fault occurs frequently, replace the sensor.
2292-12	3668412	Ultrasonic sensor 3 (GIO16) has an internal fault. If the fault occurs frequently, replace the sensor.
2293-12	3670012	Ultrasonic sensor 3 (GIO16) has an internal fault. If the fault occurs frequently, replace the sensor.
2294-12	3671612	Ultrasonic sensor 3 (GIO16) has a sensor membrane fault. Make sure that the sensor membrane is clean and the sensor has a free view. If the error continues to occur, replace the sensor.
2295-12	3673212	The cable to the ultrasonic sensor 3 (GIO16) was interrupted or a new ultrasonic sensor has not been learned yet. If the fault occurs during TailGUARD™ start-up, ignore the fault and repeat the start-up procedures.

Electronic Extension Module fault codes

Code in SmartBoard	Diagnostic Code	Description
2305-12	3689212	Ultrasonic sensor 4 (GIO16) has an internal fault. If the fault occurs frequently, replace the sensor.
2308-12	3694012	Ultrasonic sensor 4 (GIO16) has an internal fault. If the fault occurs frequently, replace the sensor.
2309-12	3695612	Ultrasonic sensor 4 (GIO16) has an internal fault. If the fault occurs frequently, replace the sensor.
2310-12	3697212	Ultrasonic sensor 4 (GIO16) has a sensor membrane fault. Make sure that the sensor membrane is clean and the sensor has a free view. If the error continues to occur, replace the sensor.
2311-12	3698812	The cable to the ultrasonic sensor 4 (GIO16) was interrupted or a new ultrasonic sensor has not been learned yet. If the fault occurs during TailGUARD™ start-up, ignore the fault and repeat the start-up procedures.
2321-12	3714812	Ultrasonic sensor 5 (GIO16) has an internal fault. If the fault occurs frequently, replace the sensor.
2324-12	3719612	Ultrasonic sensor 5 (GIO16) has an internal fault. If the fault occurs frequently, replace the sensor.
2325-12	3721212	Ultrasonic sensor 5 (GIO16) has an internal fault. If the fault occurs frequently, replace the sensor.
2326-12	3722812	Ultrasonic sensor 5 (GIO16) has a sensor membrane fault. Make sure that the sensor membrane is clean and the sensor has a free view. If the error continues to occur, replace the sensor.
2327-12	3724412	The cable to the ultrasonic sensor 5 (GIO16) was interrupted or a new ultrasonic sensor has not been learned yet. If the fault occurs during TailGUARD™ start-up, ignore the fault and repeat the start-up procedures.
2337-12	3740412	Ultrasonic sensor 6 (GIO16) has an internal fault. If the fault occurs frequently, replace the sensor.
2340-12	3745212	Ultrasonic sensor 6 (GIO16) has an internal fault. If the fault occurs frequently, replace the sensor.
2341-12	3746812	Ultrasonic sensor 6 (GIO16) has an internal fault. If the fault occurs frequently, replace the sensor.
2342-12	3748412	Ultrasonic sensor 6 (GIO16) has a sensor membrane fault. Make sure that the sensor membrane is clean and the sensor has a free view. If the error continues to occur, replace the sensor.
2343-12	3750012	The cable to the ultrasonic sensor 6 (GIO16) was interrupted or a new ultrasonic sensor has not been learned yet. If the fault occurs during TailGUARD™ start-up, ignore the fault and repeat the start-up procedures.
2352-03	3763503	The LIN bus to the ultrasonic sensors (GIO16) was interrupted by excessive voltage. Check the sensor cable.
2352-04	3763604	The LIN bus to the ultrasonic sensors (GIO16) has a short to ground. Check the sensor cable.
2352-05	3763705	No sensor is connected on the line of the LIN bus to the ultrasonic sensors (GIO16).
2352-09	3764109	The LIN bus to the ultrasonic sensors (GIO16) is having communication problems. Switch the ignition off and on again.
2353-13	3766113	The ultrasonic sensors (GIO16) are not configured.
2368-02	3789002	The reversing signal is not available or is outside the valid range. Check the CAN connections of the 24 V CAN on port GIO12 to the vehicle.

Electronic Extension Module fault codes

Code in SmartBoard	Diagnostic Code	Description
2368-12	3790012	The reverse signal is implausible. Switch the ignition off and on again. Drive the vehicle and then engage the reverse gear while stationary. Check the reverse signal for a short-circuit to supply voltage.
2384-03	3814703	The pressure sensor input has a short-circuit to supply voltage. Check the cabling.
2384-04	3814804	The pressure sensor input has a short-circuit to ground. Check the cabling.
2384-14	3815814	The pressure sensor detects a braking pressure although no brake is being applied. Check the proper function of the pressure sensor and the solenoid valves if applicable and the Select-High valve for tightness.
2385-03	3816303	The supply cable for the pressure sensor has a short-circuit to supply voltage. Check the cabling.
2385-04	3816404	The supply cable for the pressure sensor has a short-circuit to ground. Check the cabling.
2400-05	3840505	The supply cable for the stop light (GIO12, pin 1) is not connected. The stop light cannot be actuated. Check the cabling.
2416-00	3865600	Supply pressure of the reverse monitoring system is too high. Check the supply pressure, the pressure limiting valve and the pressure sensor.
2416-01	3865701	Supply pressure of the reverse monitoring system is too low.
2432-12	3892412	The pressure sensor detects a braking pressure at a vehicle speed that is too high or invalid. Check the TailGUARD™ valves for leaks as well as the valves and the pressure sensor and their cables for short circuits to supply.
2448-03	3917103	The status lamp or its cable has a short-circuit to supply voltage. Check the cabling.
2448-04	3917204	The status lamp or its cable has a short-circuit to ground. Check the cabling.
2448-05	3917305	The status lamp or its cable is not connected. Check the cabling; if an LED is installed, install and additional 1 kOhm resistor to ground.
2464-03	3942703	The warning lamp or its cable has a short-circuit to supply voltage. Check the cabling.
2464-04	3942804	The warning lamp or its cable has a short-circuit to ground. Check the cabling.
2464-05	3942905	The warning lamp or its cable is not connected. Check the cabling.
2480-03	3968303	The cable for the brake signal has a short-circuit to supply voltage. Check the cabling.
2480-04	3968404	The cable for the brake signal has a short-circuit to ground. Check the cabling.
2480-05	3968505	The cable for the brake signal is not connected. Check the cabling.
2496-09	3994509	Trailer Remote Control communication switched off because an existing Trailer Remote Control communication was detected via another electronic extension module. Disable all Trailer Remote Control communications in all Electronic Extension Modules except the first one (with the TailGUARD™ system).
2512-12	4020412	The brake request from the TailGUARD™ system was not acknowledged by the towing vehicle. Check the cabling of GIO13, pin 1 (brake signal), and GIO13, pin 3 (brake status signal). It is possible that the fault can be ignored (additional information under "Info").

Electronic Extension Module fault codes

Code in SmartBoard	Diagnostic Code	Description
2513-12	4022012	The truck indicates confirmation of a TailGUARD™ braking action even though the TailGUARD™ system has not requested braking. Note the additional information ("Info" button), it may be possible to ignore the fault.
2514-12	4023612	The brake signal has a short-circuit to the brake confirmation signal (short-circuit GIO13, pin 1, to GIO13, pin 3). Check the cabling.
2944-09	4711309	No CAN connection to Trailer EBS.
2945-09	4712909	No CAN connection to truck. Check the cabling of the CAN lines of the Electronic Extension Module power cable (pins 2 and 3 / white-green and white-brown lines) to the vehicle (body manufacturer CAN port).
3520-09	5632909	CAN connection to towing vehicle via ISO 12098 interrupted.
4000-03	6400303	The supply voltage of the ultrasonic sensors is too high.
4000-04	6400404	The supply voltage of the ultrasonic sensors is too low. This fault can also occur in combination with the fault "Power supply too low", then ignore.
4016-03	6425903	The supply voltage to the Electronic Extension Module is above 30 V.
4016-04	6426004	The supply voltage to the Electronic Extension Module is below 9 V.
4017-03	6427503	The supply voltage to the Electronic Extension Module is too high. The reverse monitoring system was switched off.
4017-04	6427604	The supply voltage for the Electronic Extension Module is below 19 V. The reverse monitoring system was switched off.
4048-14	6478214	The TailGUARD™ system has not been learned or tested yet. Please run initial start-up routine.
4049-02	6478602	The parameter settings are incorrect. For more information: Read out parameter set and write back into the ECU.
4064-12	6503612	The port expansion was deactivated. Too many 12 V components were defined on the Electronic Extension Module in multi-voltage operation. Reduce the number to max. 3 components.
4065-12	6505212	Switch ignition off for at least 5 s. If the fault is still current after the ignition reset, contact your WABCO partner.
4066-12	6506812	Switch ignition off for at least 5 s. If the fault is still current after the ignition reset, contact your WABCO partner.
4067-12	6508412	Switch ignition off for at least 5 s. If the fault is still current after the ignition reset, contact your WABCO partner.
4068-12	6510012	Switch ignition off for at least 5 s. If the fault is still current after the ignition reset, contact your WABCO partner.
4069-12	6511612	Switch ignition off for at least 5 s. If the fault is still current after the ignition reset, contact your WABCO partner.
4088-12	6542012	Switch ignition off for at least 5 s. If the fault is still current after the ignition reset, contact your WABCO partner.

WABCO regional offices

12 WABCO regional offices

	WABCO Headquarters, Giacomettistrasse 1, 3006 Bern 31, Switzerland, Tel.: +32-2663 98 00		
	WABCO Europe BVBA Chaussée de la Hulpe 166 1170 Brüssel Belgium Tel.: +32 2 663 9800 Fax: +32 2 663 9896		WABCO Belgium BVBA/ SPRL 't Hofveld 6 B1-3 1702 Groot-Bijgaarden Belgium Tel.: +32 2 481 09 00
	WABCO GmbH Am Lindener Hafen 21 30453 Hannover Germany Tel.: +49 511 9220		WABCO GmbH Gartenstraße 1 31028 Gronau Germany Tel.: +49 511 922 3000
	WABCO brzdy k vozidlům spol. s r.o. Sourcing & Purchasing Office U Trezorky 921/2 Prague 5 Jinonice 158 00 Prag Czech Republic Tel.: +420 226 207 010		WABCO brzdy k vozidlům spol. s r.o. Pražákova 1008/69, Štýřice, 639 00 Brno Czech Republic Tel.: +420 543 428 800
	WABCO (Schweiz) GmbH Morgenstrasse 136 Bern 3018 Switzerland Tel.: +41 31 997 41 41		WABCO International Sourcing & Purchasing Office Harmandere Mh. Dedepasa Cd. 24 Atlas Park B/5 Pendik, 34912 Istanbul Turkey Tel.: +90 216 688 81 72 Fax: +90 216 688 38 26
	WABCO Carre Hausmann 1 cours de la Gondoire 77600 Jossigny France Tel.: +33 1 87 21 13 12		WABCO Automotive Italia S.r.L. Studio Tributario e Societario, Galleria San Federico 54 Torino, 10121 Italy Tel.: +39 011 4010 411
	WABCO España S. L. U. Av de Castilla 33 San Fernando de Henares Madrid 28830 Spain Tel.: +34 91 675 11 00		WABCO Automotive AB Drakegatan 10, Box 188 SE 401 23 Gothenburg Sweden Tel.: +46 31 57 88 00
			WABCO Automotive U.K. Ltd Unit A1 Grange Valley Grange Valley Road, Batley, W Yorkshire, United Kingdom, WF17 6GH Tel.: +44 (0)1924 595 400

WABCO regional offices

	WABCO Australia Pty Ltd Unit 3, 8 Anzed Court Mulgrave, Victoria 3170 Australia Tel.: +61 3 8541 7000 Hotline: 1300-4-WABCO		WABCO do Brasil Indústria e Comércio De Freios Ltda Rodovia Anhanguera, km 106 CEP 13180-901 Sumaré-SP Brazil Tel.: +55 19 2117 4600 Tel.: +55 19 2117 5800		WABCO Hong Kong Limited 14/F Lee Fund Centre 31 Wong Chuk Hang Road Hong Kong China Tel.: +852 2594 9746
	Asia Pacific Headquarters, WABCO (Shanghai) Mgmt Co. Ltd 29F & 30F, Building B, New Caohejing Intl Bus. Center 391 Guiping Rd, Xuhui Dist. Shanghai 200233, China Tel.: +86 21 3338 2000		WABCO (China) Co. Ltd. Jinan Shandong WABCO Automotive Products Co. Ltd. 1001 Shiji Av, Jinan Indust. Zone, Shandong 250104 China Tel.: +86 531 6232 8800		WABCO (China) Co. Ltd No. 917 Weihe Road, Economic & Tech. Dev. Zone Qingdao 266510 China Tel.: +86 532 8686 1000
	WABCO (China) Co. Ltd Guangdong WABCO FUHUA Automobile Brake System Co. Ltd. Building E, No. 1 North, Santai Av, Taishan City Guangdong 529200 China Tel.: +86 750 5966 123		Shanghai G7 WABCO IOT Technology Co. Ltd Room 503, Liguobu Building, No. 255 Wubao Road, Minhang Dist. Shanghai 201100 China Tel.: 021-64058562/826		China-US RH Sheppard Hubei Steering Systems Co. Ltd No. 18, Jingui Road, Xianning City Hubei 437000 China
	WABCO India Limited Plot No. 3 (SP), III Main Road Ambattur Industrial Estate Chennai 600 058 India Tel.: +91 44 42242000		WABCO Japan Inc Gate City Ohsaki W. Tower 2F, 1-11-1, Osaki, Shinagawa-ku, Tokyo 141-0032 Japan Tel.: +81 3 5435 5711		WABCO Korea Ltd 23, Cheongbulsandan-ro, Cheongbuk-eup Pyongtaek-si Gyeonggi-do, 17792 Korea Tel.: +82 31 680 3707
	WABCO Asia Private Ltd 25 International Business Park #03-68/69 German Centre 609916 Singapore Tel.: +65 6562 9119		WABCO Automotive SA 10 Sunrock Close Sunnyrock Ext 2, Germison 1401 PO Box 4590, Edenvale 1610 South Africa Tel.: +27 11 450 2052		WABCO Middle East and Africa FZCO Vehicle Control System DWC Business Park, Building A3, Room NO: 115, PO Box 61231, Dubai United Arab Emirates E-mail: info.dubai@wabco-auto.com



You can find information on WABCO products here: <https://www.wabco-customercentre.com>
Please contact your WABCO partner for further information.

ZF Friedrichshafen AG

ZF is a global technology company and supplies systems for passenger cars, commercial vehicles and industrial technology, enabling the next generation of mobility. ZF allows vehicles to see, think and act. In the four technology domains Vehicle Motion Control, Integrated Safety, Automated Driving, and Electric Mobility, ZF offers comprehensive solutions for established vehicle manufacturers and newly emerging transport and mobility service providers. ZF electrifies different kinds of vehicles. With its products, the company contributes to reducing emissions and protecting the climate.

ZF, which acquired WABCO Holdings Inc. on May 29, 2020, now has 162,000 employees worldwide with approximately 260 locations in 41 countries. In 2019, the two then-independent companies achieved sales of €36.5 billion (ZF) and \$3.4 billion (WABCO).

With the integration of WABCO, the leading global supplier of braking control systems and other advanced technologies that improve the safety, efficiency and connectivity of commercial vehicles ZF will create a new level of capability to pioneer the next generation of solutions and services for original equipment manufacturers and fleets globally. WABCO, with almost 12,000 people in 40 locations worldwide, will now operate under the ZF brand as its new Commercial Vehicle Control Systems division.

